

REASONING WITH SHAPES: SOME OBSERVATIONS FROM A CASE STUDY

Amaresh Chakrabarti

Engineering Design Centre, Department of Engineering
University of Cambridge
Trumpington Street, Cambridge
United Kingdom

Burkhard Wolf

TH Darmstadt
Institut für Maschinenelemente und Konstruktionslehre
Magdalenenstr. 4, Darmstadt
Germany

ABSTRACT

Reasoning with shapes plays an essential role in mechanical design. Therefore, developing methods and techniques for supporting this activity is an important goal of design research. As a pre-requisite to this, it is crucial to understand how designers create, modify and consolidate shapes, and based on these, to identify areas where they need to be, and can be supported.

The goal of this paper is to report some observations about the influencing factors and processes involved in reasoning with shapes, based on a case study of an in-house design project. Three questions were asked: (i) where did the initial ideas originate and why, (ii) what were the reasons for changing/modifying these, and how these changed, and, (iii) where did this stop and why.

This paper provides a description and the results of the case study, involving observations and analyses of the above steps. The observations indicate that shape generation and modification is more significantly influenced by (i) the initial state of the design, (ii) identification, contextualisation and selection of criteria to apply for evaluation of that design state, and (iii) on the quality of evaluation of the design state, than by the generative changes, which often are simple adaptations of existing solutions.

1. INTRODUCTION

1.1 Goal of this paper

The goal of this paper is to report some observations, from an in-house design project case study called the mobile arm support project conducted at the Cambridge Engineering Design Centre, about how reasoning with shapes takes place. The design was done by a number of designers, some novice

and some experienced, and was done partly in teams and partly by individual designers.

1.2 The Mobile Arm Support Project

The mobile arm support (MAS) project is an on-going project at the Cambridge Engineering Design Centre (EDC) aimed at designing and developing a means for increasing the arm mobility of people with muscular dystrophy and atrophy. These people are wheelchair bound, and have very little strength in their arms; this makes them, at present, dependent entirely on carers even for their most basic daily activities. One aim of the project is to develop an arm support to provide vertical and horizontal mobility of their arms.

An arm support was developed for mark I of the project to provide a 'proof of a concept'. This had three main sub-assemblies: (i) a for-bar linkage arm mechanism, with an arm rest, having enough degrees of freedom for horizontal movement of the arm, (ii) a lead screw actuator mechanism, powered by a dc motor-gearbox mechanism, attached through a tie-rod to the arm mechanism to provide powered vertical motion, and (iii) an attachment mechanism which attaches the actuator-arm-support assembly to the wheelchair. The prototype was tested for functionality and ease of operation. Its performance was satisfactory; using this arm support, for instance, one test-person could manage to eat un-aided for the first time in twenty five years. However, it had a number of problems: the arm support provided Cartesian type un-natural arm movement, it was heavy and expensive, had an unpleasant engineering look, and did not fit into a range of wheelchairs. The mark II phase of the project started this year with the aim of improving the mark I prototype for improved functionality, aesthetics, cost, and weight with the aim of enabling it to fit into a range of wheel chairs.

Design of the attachment mechanism was considered as a problem having two main functions: the design must be able to hold the actuator-arm-support assembly in a vertical position, and it must attach to a range of wheelchairs (see Fig. 1). The design process involved simultaneous development of three functional means: (i) a means for holding the actuator-arm-support assembly, (ii) a means for attachment to the wheelchair, and (iii) a means for connecting these two. It was found, from investigation into a range of wheelchairs for possible common attachment points, that the only commonality between the wheelchairs designs are their tubular frames, with nearly vertical backrest tubes. These were the natural choice as attachment points. As the wheelchair tubes were not exactly vertical, adjustability of the attachment was important for achieving verticality of the actuator assembly. This led to the simple solution of a plane vertical bracket to which the actuator can be mounted, and which can be adjusted to provide the vertical adjustment. With this decision, problem (ii) above, a means for attachment to the wheelchair, becomes that of attaching an adjustable vertical plane to the nearly vertical wheelchair tube. In this paper, we will concentrate only on the design of this means, which, henceforth, will be referred to as the design of the clamping mechanism.

1.3 Method of Research

The design process was recorded using semi-formal means such as Integrated Design Framework pigeon holes and documentation (Ball and Bauert, 1992), as well as using informal means such as designers' notebooks and minutes of the meetings. This material was then chronologically structured around each sub-assembly design. Finally, the designers were retrospectively interviewed (i) to check and ensure that the information thus structured was accurate, and (ii) to identify the causal connections between various parts of this information. The designers were asked essentially three questions: (i) what the sources of their initial ideas were and why, (ii) what the reasons for changing/modifying these ideas were, and how they changed them, and, (iii) when the modifications stopped and why. Based on this information, it was attempted to draw a coherent picture of the designers' reasoning processes, and then, based on this, an attempt was made to seek for possible answers to these questions:

- (i) What are the processes which lead to shape evolution?
- (ii) What kind of knowledge is used during the shape evolution process?

2. CASE STUDY AND OBSERVATIONS

2.1 Specification

The overall specification of the attachment design problem consisted of customer and engineering requirements pertaining to various aspects of the design and operation cycle, such as geometry, forces, material, safety, ergonomics, aesthetics, manufacture, assembly, environment and operation. The following six features were especially important for the design (Wolf, 1994) : low cost, easy

dismounting without loss of adjustment, adjustable angle of the actuator axis, few components, discreet design, and fitting to many wheelchair designs.

From the above specification, the specific requirements relevant for the design of the clamping mechanism were:

- The design be able to hold the actuator to the wheelchair tube, and should allow adjustment of the angle of the actuator.
- It should require as little machining/manufacturing as possible.
- It should be easy to install.
- It should be cheap.
- It should have a pleasing aesthetics.

2.2. Design Process of the Clamping Mechanism

As mentioned in the introduction, the wheelchair 'vertical' tubes of the backrest frame were not exactly vertical, while the actuator axis had to be kept vertical; this was required to ensure that no vertical forces were required for the users to move the arm support at a given position of the actuator. This led to the requirement that the actuator angle should be adjustable. A vertical plane, with adjustable attachment points, was thought of as a simple solution to the adjustment problem, and therefore, a vertical plane bracket was chosen. The idea was that a clamping mechanism would attach this bracket to the 'vertical' wheelchair tube, and the actuator would be attached to the bracket (see Fig. 2).

The clamp mechanism problem therefore became that of attaching a plane to the wheelchair tube. Several existing clamps were investigated as potential solutions, which included the clamp design for mark I phase of the MAS project. In mark I design (see Fig. 3), the clamp is a split round bar with two vertical holes; perpendicular to these holes, and between them, it has a hole for using a single Allen screw for tightening the clamp. One of the two vertical holes was used to hold the wheelchair tube, and the other for holding an intermediate tube to which the MAS-I actuator assembly was to be attached. This clamp had the advantage that it was strong, small, required only one screw (and one tool, namely an Allen key) for fastening, and has a pleasing aesthetics. Most important of all, it required a single attachment point on the wheelchair, unlike all but one other clamp under consideration. A single attachment point was all that was common in a range of wheelchairs, and thus was an important constraint if one had to design an attachment suitable for a range of wheelchairs. The other clamp which satisfied the single point attachment criterion was estimated, however, to be lot more expensive than the MAS-I clamp. MAS-I clamp was therefore taken as a starting point for MAS II clamp design.

However, as the MAS-I clamp was designed to connect two parallel tubes, it transmitted any error in verticality in the wheelchair tube to the other tube, and thus was not suitable for the adjustability requirement. It had to be modified now to connect a plane with the wheelchair tube, as discussed before, while looking for satisfaction of the other requirements. It was detected that the MAS-I design already

had a plane (see Fig. 4) to which a plane bracket can be attached. As attaching a plane would require at least two attaching points, two holes for screw attachment, one on each split part, are envisaged as modification. Now that the second vertical hole, previously required for attaching the intermediate tube, was no longer necessary, it was discarded. The design now looked like that in Fig. 5.

However, now the fastener is at one end of the clamp, while the tube and the plane to be attached are at the other end. Tightening the fastener causes the two parts of the clamp apart in an angular fashion (henceforth, this will be referred to as the forking problem, causing the plane and the fasteners to have mismatch and bending (see Fig. 6), and a solution to this problem is necessary. One potential solution considered was to put an extra fastener between the attaching plane and the hole for the wheelchair-tube (see Fig. 7). This would have the problem of interference between the holes for attaching the bracket plane to the clamp and the fastener hole

It was identified at this stage that if a solid bar was used instead of a split bar, the above problem of deformation due to tightening would be eliminated. However, in that case attaching wheelchair tube with the clamp would be impossible; this could be solved by providing a continuous slot spanning all the way to the hole for wheelchair tube (see Fig. 8). This, however, would have the problem of bending of the clamp sides, when the screw is tightened.

At this point, another clamp design [King, 1994], by chance, came to the notice of the designer in charge. This was similar to the split round bar design (Fig. 5) except for a square block instead of a round one (see Fig. 9). This design has a brass pivot at one end, and a screw between the pivot and the hole for the wheelchair tube, to prevent the forking problem. In order to be able to attach the plane bracket to this clamp, it is modified exactly as the split round bar solution, i.e., by making two holes, one on each split part (see Fig. 10). This design has (one or two) brass parts to prevent forking. In order to eliminate these extra parts, this solution was dreamed up. It was understood at this stage that standard parts were not available, and that the clamp is produced by drilling holes into a metal block and then milling the block into two. If this milling is done such that two bits of shoulder are left uncut (see Fig. 11), these can be used to provide the function that the brass parts provide.

Now the design has four holes: two for attaching the plane, one for wheelchair tube, and one for the tightening screw. Can this number be reduced? It is recognised at this point that now there is another plane on the clamp to which the plane bracket can be attached (see plane 2 in Fig. 12). As one needs two attachment points for attaching a plane bracket, the solution now looks like the one in Fig. 13. It is recognised that these same fasteners can be used for attaching the clamp to the wheelchair tube, reducing the number of holes to three.

Now that the side holes were no longer necessary, it was recognised that hollow, instead of solid, square tubes, cut into half would lead to considerable reduction of material. The pivots would no longer be required if the tube when cut takes a layer of material out so that the halves of the hole for the

wheelchair tube were no longer half circles (see Fig. 14). Milling a hollow square tube into half was still an expensive manufacturing operation, and as a further reduction the use of two U-channels to approximate split hollow square tube was considered. This was discarded on a second thought, as it was suspected at this point that holding two channels together to drill the hole for the wheelchair tube would make two semi-circles which together would not be able to provide required clamping action (see Fig. 15). This suspicion, however, was cleared by a consultation with the workshop manager who suggested the use of U-channels as a cost improvement and assured that the required hole-halves can be obtained by drilling the hole while the channels are spaced slightly apart from each other.

The final design is shown in Fig. 15. This design uses stock material almost directly, and sawing (pieces of material) and drilling are the only manufacturing operations required. The number of holes required is also been reduced to a minimum. It is therefore cheap. However, mounting is tricky as both the clamp and the bracket are to be clamped simultaneously. Notwithstanding this problem, it was decided by the designer at this point that this was the best he could do, which prompted him to stop doing further modifications.

2.3 Summary of Observations

- Design Process seems to be sequential; one problem was considered at a time, with frequent shuttling between problems.
- Designing is a problem identification and problem solving process: the steps are: evaluate an existing/modified design for various criteria to identify its suitability and problems, modify the design, and evaluate it for suitability.
- There are essentially four processes in design: (i) identification of criteria for generation, modification or evaluation, (ii) generation or modification, (iii) evaluation and further problem identification, and, (iv) selection.
- A complex knowledge base is used to carry on these processes: the designs considered almost always had functional, behavioural, structural, operational, manufacturing and assembly knowledge associated with them.
- Part of the identification of criteria was direct use of the specification. Another major source was a repertoire of principles such as simplicity, use of standard parts, reduction of material, elimination of redundant or un-necessary parts, etc. Further criteria were derived from the specification by considering them with respect to specific contexts, i.e., specific design states, principles, etc.
- Generation/ modification was done in either of the following two ways: one was the use of standard stock materials or parts or existing sub-assemblies, and the other was making small changes to these, either by using other standard materials/assemblies etc., or with simple geometric changes based on removal of materials for specific operations or uses.
- Evaluation was heavily dependent on which criteria were used, and how well they were applied. This latter activity was dependent on both the quality of the knowledge base of the

design (as described above), and the ability to visualise based on this knowledge.

- Selection was observed to be dependent on designer's satisfaction level, and his belief on what can be achieved at a given state.
- Criteria were continued to be identified as design progressed.
- Only part of the criteria is used for one generation, modification or evaluation.
- As modification depends on the state of the design one starts with as well as the criteria chosen for evaluation at that state, modification guarantees betterment of a design only with respect to these specific criteria. However, it does not guarantee that the design after modification is better on the whole than the design before modification. This leaves chances for circular processing (Deja-vu effect!).
- Modification also depends on serendipity, visualisation ability, orderings of which criteria are chosen at a given state, the state of knowledge of the designer, assumptions made at a given state and the confidence of the designer on these assumptions. Therefore, these, along with the starting state of the design and the criteria chosen at that state, are some of the variables which determine the outcome of a design process.

3. CONCLUSIONS RELATED WORK, AND FURTHER RESEARCH

Shape evolution is as messy as it appears from the above descriptions. Shape generation/modification is more significantly influenced by (i) the initial state of the design, (ii) identification and contextualisation and selection of criteria to apply for evaluation of that design state, and (iii) the quality of evaluation of the design state, than by the generative changes, which often are simple adaptations of existing solutions.

Related works include case studies by Hales (1987), Stauffer et al. (1987), Ehrlenspiel and Dylla (1989) and Fricke and Pahl (1991), Blessing (1994), although none focuses specifically on the influences on shape emergence. Computational methods for generation and simulation have also been under development: Hoover and Rinderle (1989), Ulrich and Seering (1989), Finger and Rinderle (1990), Chakrabarti (1991), Faltings (1990), Joskowicz and Sacks (1991) are to name a few. However, they propose methods by which these could be done, not models of how these are done. The above are preliminary observations of the case study. Further work would focus on two sub-tasks:

- A more rigorous and complete investigation of the case study.
- Based on the investigation, identification of requirements for design tools and methods for supporting shape evolution.

REFERENCES

Ball, N.R., and Bauert, F., 1992, "The integrated design framework: supporting the design process using a blackboard system", *Artificial Intelligence in Design '92*, J.S. Gero, ed., Dordrecht: Kluwer Academic, pp. 327-348.

Wolf, B., 1994, "Systematic Design of the attachment for a mobile arm support", Konstruktiver Entwurf, Technische Hochschule Darmstadt and Cambridge University.

Blessing, L.T.M., 1994, "A Process Based Approach to Computer Supported Engineering Design," PhD Thesis, University of Delft, The Netherlands.

Chakrabarti, A., 1991, "Designing by Functions," Ph.D. Thesis, Department of Engineering, Cambridge University, UK.

Dylla, N., 1990, "Denk- und Handlungsabläufe beim Konstruieren," PhD Thesis, Technische Universität München, Fakultät für Maschinenwesen, München.

Ehrlenspiel, K., and Dylla, N.D., 1989, "Experimental Investigation of the Design Process", *Proceedings of the International Conference on Engineering Design*, Harrogate, Vol. 1, pp. 77-95.

Faltings, B., 1990, "Qualitative Kinematics in Mechanisms", *Artificial Intelligence*, Vol. 44, pp. 89-119.

Finger, S., and Rinderle, J.R., 1990, "A Transformational Approach for Mechanical Design Using a Bond Graph Grammar", EDRC Report no. 24-23-90: Carnegie-Mellon University, USA.

Fricke, G., and Pahl, G., 1991, "Zusammenhang zwischen personenbedingtem Vorgehen und Lösungsgüte," *Proceedings of the International Conference on Engineering Design*, Zürich, Vol. 1, pp. 331-341.

Hales, C., 1987, "Analysis of the Engineering Design Process in an Industrial Context," PhD Thesis, University of Cambridge, UK.

Hoover, S.P., and Rinderle, J.R., 1989, "A Synthesis Strategy for Mechanical Devices", *Research in Engineering Design*, Vol. 1, pp. 87-103.

Joskowicz, L., and Sacks, E.P., 1991, "Computational Kinematics," *Artificial Intelligence*, Vol. 51, pp. 381-416.

King, T., 1994, Personal Communication, Cambridge, UK.

Stauffer, L.A., Ullman, D.G., and Dieterich, T.G., 1987, "Protocol Analysis of Mechanical Engineering Design," *Proceedings of the International Conference on Engineering Design*, Boston, Vol. 1, pp. 74-85.

Ulrich, K.T., and Seering, W.P., 1989 "Synthesis of Schematic Descriptions in Mechanical Design," *Research in Engineering Design*, vol. 1, no. 1, pp. 3-18.

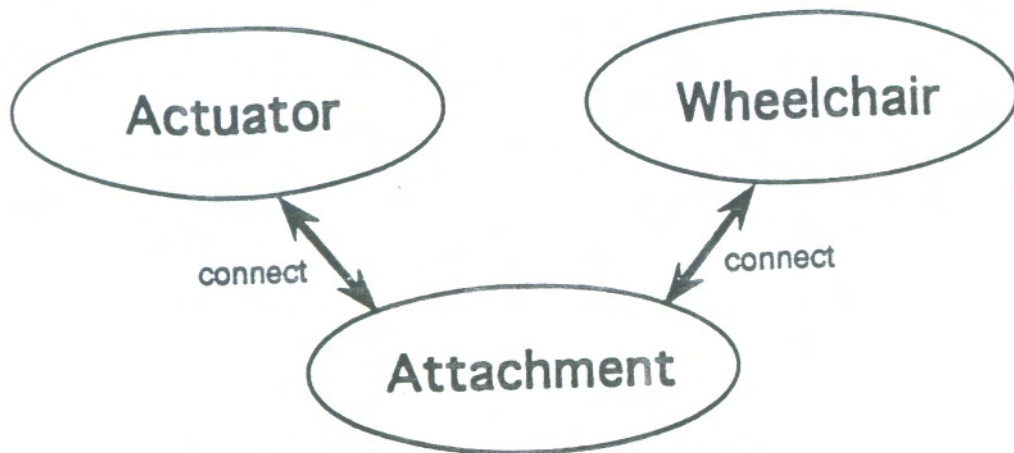

FIG.1: THE MAIN FUNCTIONS OF THE ATTACHMENT MECHANISM

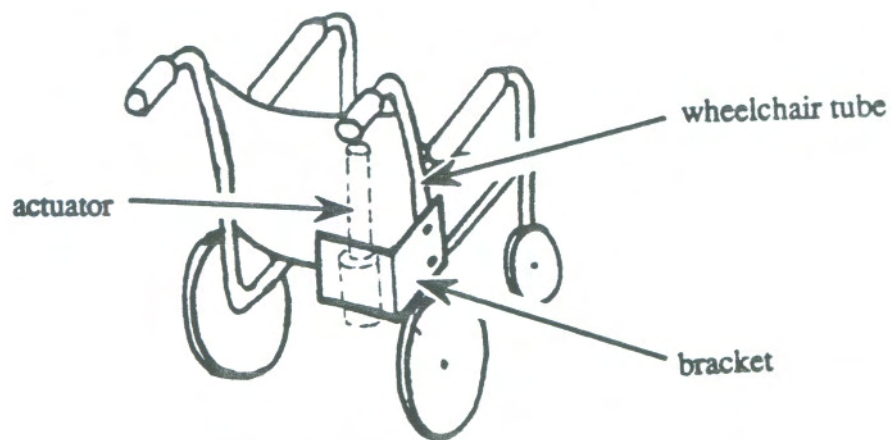

FIG. 2: GENERAL LAYOUT OF THE ATTACHMENT

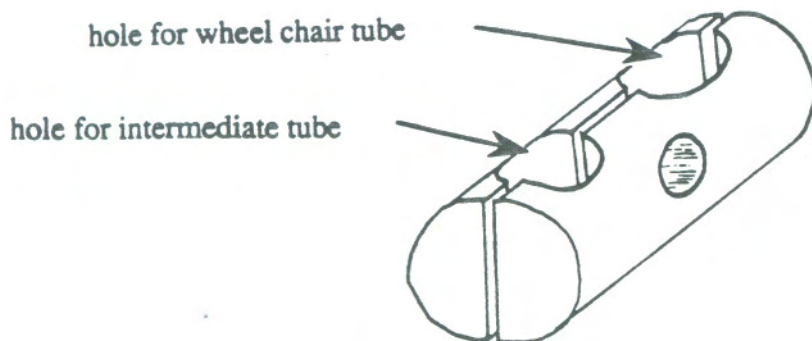

FIG. 3: CLAMP DESIGN FOR THE MARK I PHASE OF THE MAS PROJECT

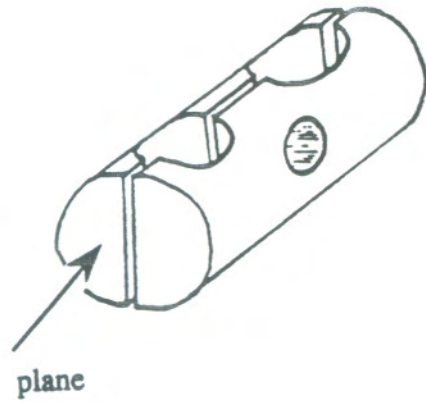

FIG. 4: PLANE FOR ATTACHING THE BRACKET IN MARK I CLAMP DESIGN

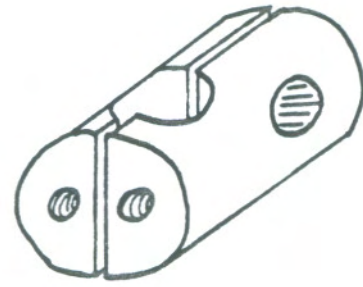

FIG. 5: MODIFIED MAS I CLAMP

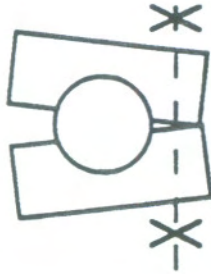

FIG. 6: ATTACHMENT PROBLEM WITH THE MODIFIED MAS I CLAMP DESIGN

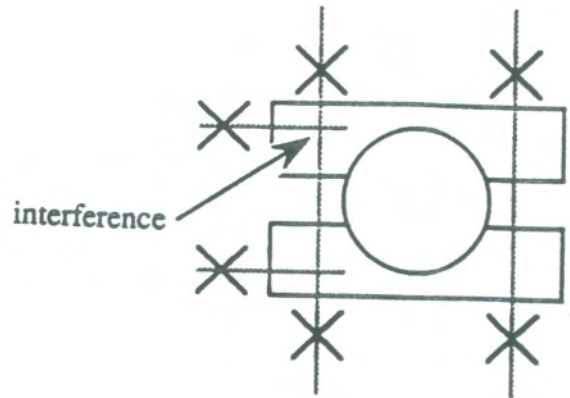

FIG. 7: INTERFERENCE BETWEEN HOLES

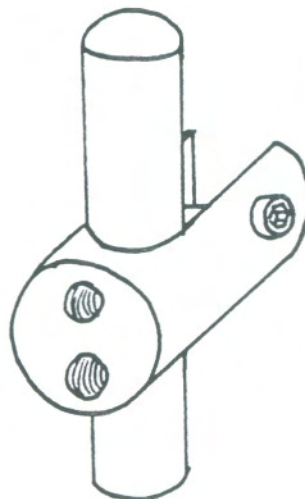

FIG. 8: CLAMP DESIGN WITH CONTINUOUS SLOT

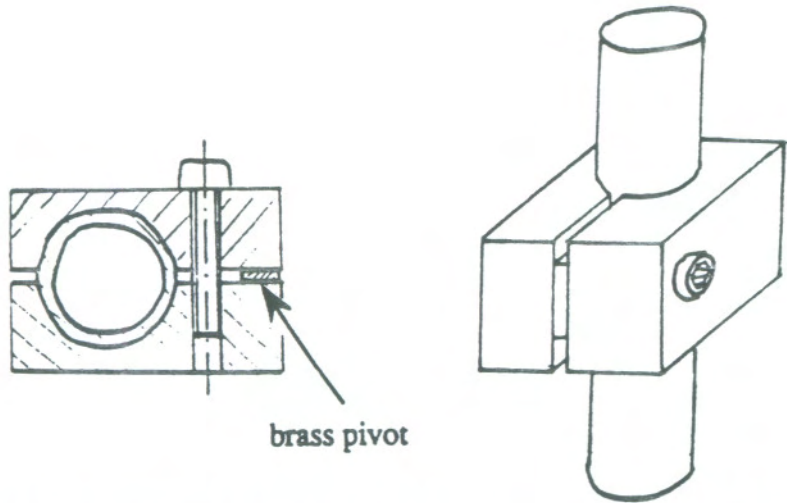

FIG. 9: THE SQUARE CLAMP DESIGN ACCIDENTALLY NOTICED BY THE DESIGNER

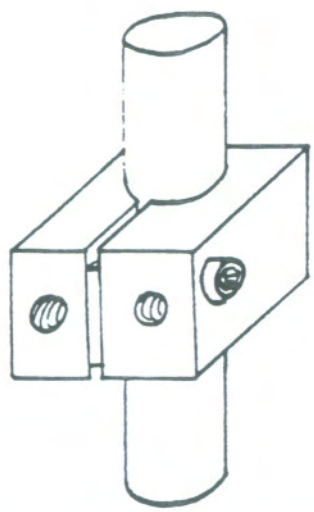

FIG. 10: MODIFIED SQUARE CLAMP DESIGN

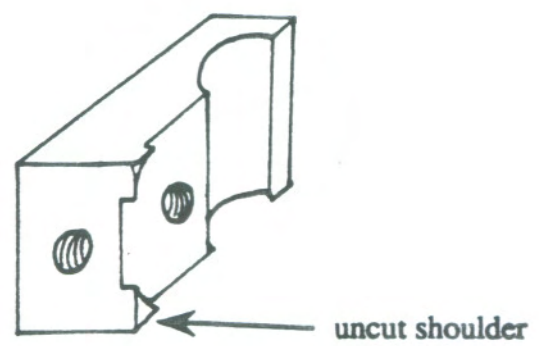

FIG. 11: PIVOT FEATURE MODIFICATION OF THE MODIFIED SQUARE CLAMP DESIGN

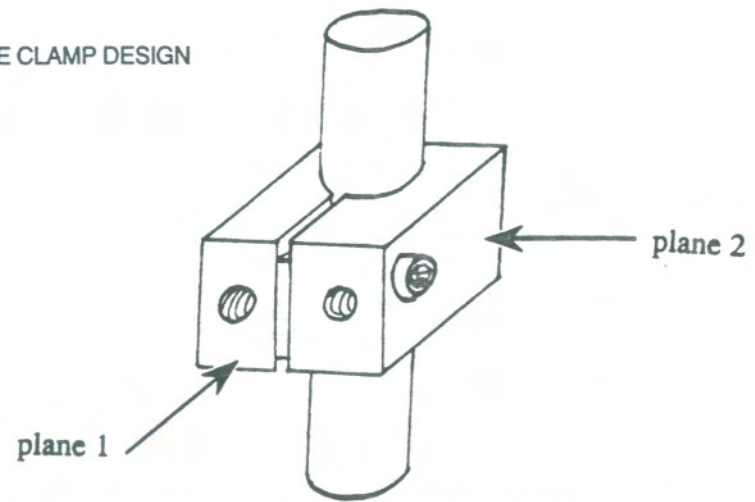

FIG. 12: ALTERNATIVE ATTACHING PLANES IN THE MODIFIED SQUARE CLAMP DESIGN

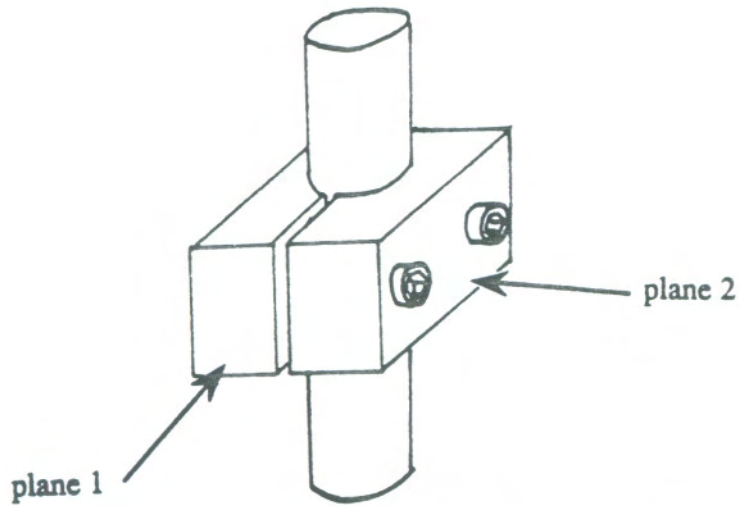

FIG. 13: MODIFIED SQUARE CLAMP DESIGN WITH ATTACHING POINTS ON PLANE 2

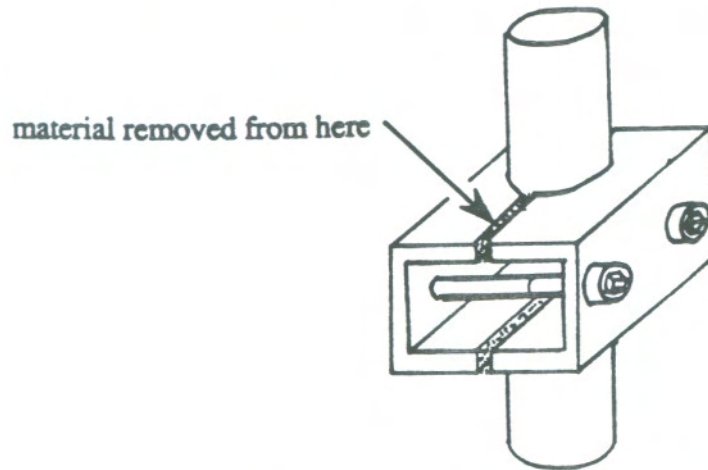

FIG. 14: CLAMP SOLUTION WITH A HOLLOW SQUARE TUBE

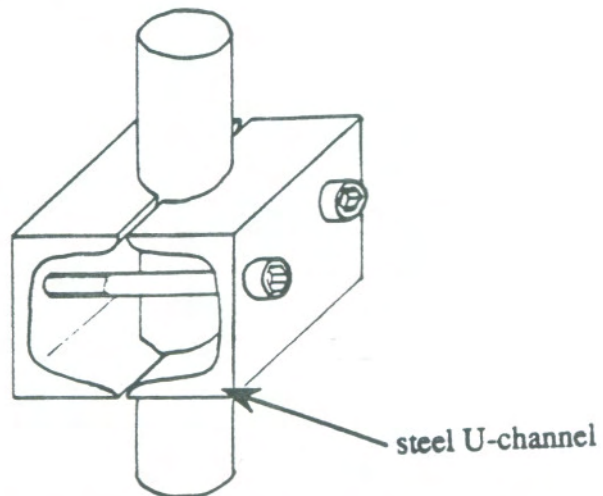

FIG. 15: FINAL CLAMP DESIGN WITH TWO U-CHANNELS