

A functional representation for aiding biomimetic and artificial inspiration of new ideas

AMARESH CHAKRABARTI,¹ PRABIR SARKAR,¹ B. LEELAVATHAMMA,¹ AND B.S. NATARAJU²

¹Centre for Product Design and Manufacturing, Indian Institute of Science, Bangalore 560012, India

²Indian Space Research Organisation Satellite Centre, Bangalore 560017, India

(RECEIVED July 1, 2004; ACCEPTED December 15, 2004)

Abstract

Inspiration is useful for exploration and discovery of new solution spaces. Systems in natural and artificial worlds and their functionality are seen as rich sources of inspiration for idea generation. However, unlike in the artificial domain where existing systems are often used for inspiration, those from the natural domain are rarely used in a systematic way for this purpose. Analogy is long regarded as a powerful means for inspiring novel idea generation. One aim of the work reported here is to initiate similar work in the area of systematic biomimetics for product development, so that inspiration from both natural and artificial worlds can be used systematically to help develop novel, analogical ideas for solving design problems. A generic model for representing causality of natural and artificial systems has been developed, and used to structure information in a database of systems from both the domains. These are implemented in a piece of software for automated analogical search of relevant ideas from the databases to solve a given problem. Preliminary experiments at validating the software indicate substantial potential for the approach.

Keywords: Behavioral Language; Biomimicry; Design by Analogy; Idea Generation; Inspiration

1. INTRODUCTION

Inspiration is useful for exploration and discovery of new solution spaces (Murakami & Nakajima, 1997). This is also indicated by several pieces of research, for example, that presence of a stimulus can lead to more ideas being generated during problem solving (Kletke et al., 2001), that stimulus-rich creativity techniques positively affect creativity (MacCrimmon & Wagner, 1994), or from empirical evidence that individuals stimulated with association lists demonstrate more creative productivity than those without the stimuli (Watson, 1989). Both artifacts and systems in natural and artificial worlds and their functionality are seen as rich sources of inspiration for idea generation. The importance of learning from nature is long recognized, and some attempts made by researchers like Vogel (1988) and French (1998) to learn from nature with product development in mind. However, unlike in the artificial domain where existing systems are routinely used for inspiration (such as in compendia, case-based rea-

soning systems, etc.), those from the natural domain are rarely used in a systematic way for this purpose.

Analogy has long been regarded as a powerful means for inspiring novel idea generation, as seen in several systems based on analogy (Bhatta et al., 1994; Qian & Gero, 1996), and creativity methods developed with the specific aim of fostering analogical reasoning (Gordon, 1961). One aim of the work reported in this paper is to initiate similar work in the area of Systematic Biomimetics for product development. The overall goal is to use inspiration from both natural and artificial worlds to help develop novel ideas to solve design problems. The overall objective is to use analogical reasoning with a functional/behavioral language to get inspirations for ideas to a given design problem.

2. OBJECTIVE AND METHODOLOGY

The specific objective of this work is to develop a computational tool for supporting designers to generate novel solutions for product design problems by providing natural or artificially inspired/analogical ideas. The current application of focus is developing novel mechanisms. The particu-

Reprint requests to: Amaresh Chakrabarti, Centre for Product Design and Manufacturing, Indian Institute of Science, Bangalore 560012, India.
E-mail: ac123@cpdm.iisc.ernet.in

lar intension is to use the corpus of the diverse motions that nature exhibits as a potent source of inspiration for solving product design problems, especially in inspiring creativity and innovation of novel products. The work is *not* about mimicking of natural phenomena, but rather getting inspired from primarily the behavioral aspects of natural phenomena. The basic idea is to first *develop two databases*: a database of natural systems (e.g., insects, plants, etc.) exhibiting diverse movements, and a database of simple to relatively complex artificial mechanical systems that are capable of providing various behaviors (e.g., vacuum cleaners, clutches, etc.). The task then is to analyze these natural and artificial systems, and develop a *behavioral language* for describing their motion behaviors. A behavioral language has a set of constructs that is used to represent the functioning of an artificial or natural system. The third task is to develop a piece of *software* with appropriate interface and reasoning procedures to aid in the following process. Designers, with a problem to solve, will explore motions of various types (from the natural or artificial systems in the databases), and use the behavioral representation developed to describe the problem in terms of the constructs of the representation; the software will then search the databases for (part of) the entries in the databases that could be used for solving the problem.

There are three major steps involved:

- create databases of natural and artificial systems;
- develop a common, behavioral language for representing these systems and their functionality; and
- develop procedures for interactive, analogical generation of alternative ideas for solving a given design problem.

In the rest of the paper, we talk about each of these steps and results.

3. DEVELOPMENT OF A DATABASE OF NATURAL SYSTEMS

As proposed, a database of natural systems has been developed, with about 100 entries from plant and animal domains. The motions analyzed are varied in both the media in which they occur, namely air, water, land, vertical space, desert, and so forth, and the way in which they occur, for example, leaping, jumping, walking, crawling, and so forth. The information collected contains details about the function, behavior, and structure of these systems as perceived in the source materials, and the types of information collected include written, diagrammatic, pictorial, and video data about the systems and their varied motions. An example of an entry is given in Figure 1, and further detail is provided in Appendix A.

4. DEVELOPMENT OF A DATABASE OF ARTIFICIAL SYSTEMS

Similar to the database of natural systems, a database of artificial systems has also been developed. Apart from con-

taining information in the categories and forms mentioned for the natural systems database (i.e., function, behavior, and structure, and written, graphical, pictorial, and video where available), animation has been provided for most of the mechanisms where video is not available. The structure of display is the same for both natural and artificial systems. An example of an entry is given in Figure 2, and detail is given in Appendix B.

5. DESCRIBING NATURAL AND ARTIFICIAL SYSTEMS AND THEIR FUNCTIONALITY

At the center of this work is the development of a uniform functional/behavioral representation for these systems. In literature, several models of functional reasoning exist, including a number of function–behavior–structure models (FBS or SBF models; Chandrasekaran, 1994; Qian & Gero, 1996; Umeda et al., 1996; Goel, 1997; Chakrabarti, 2001; Deng, 2002).

There are many views of what function is and how it should be represented. Chakrabarti and Blessing (1996) and Chakrabarti and Bligh (2001) earlier classified these into several categories, which are summarized here under three distinct views. The semantic/syntactic distinction is taken from Deng (2002):

- Systems views: functions that can be described using (largely) device parameters (system level definitions) versus those that require both device parameters and their interpretation in an environment (environment level definitions).
- Semantic views: function as input/output (I/O) flow of energy, materials, and signal (i.e., the definition used in Pahl & Beitz, 1988), and function as change of state of an object or system (e.g., the function of a pointer needle as a change of its position against a dial; D.C. Brown, personal communication, 2004).
- Syntactic views: function using an informal representation (e.g., verb–noun representation) or formal representation (e.g., a mathematical transformation).

There are many existing representations of behavior. In general, behavior is defined as how function is achieved by the structure of a device. Qualitative physics community largely maintains that behavior should be represented as a set of state transitions that a system undergoes during its operation. Bhatta et al. (1994) represent behavior of a device as a composition of the functions of its internal structural elements, in a hierarchical way. Chakrabarti and Bligh (2001) and Chakrabarti et al. (1997) use similar ideas of composition of functions of building blocks (at effect and concept levels) for synthesizing proposals of alternative ideas for satisfying a given function. What is apparent from these examples is that there can be many FBS views of the underlying causal description of the functioning of a device or a system, and the above views are but specific aspects of this

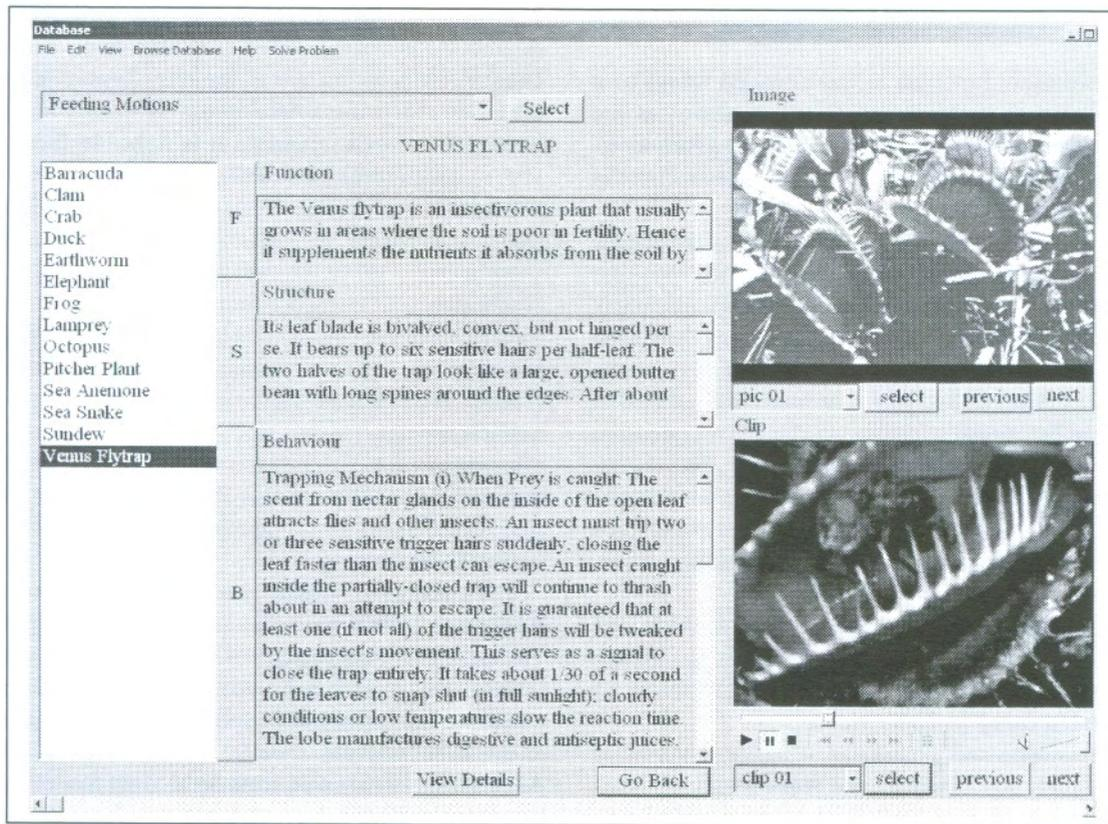

Fig. 1. A screen capture of an entry from the database of natural systems.

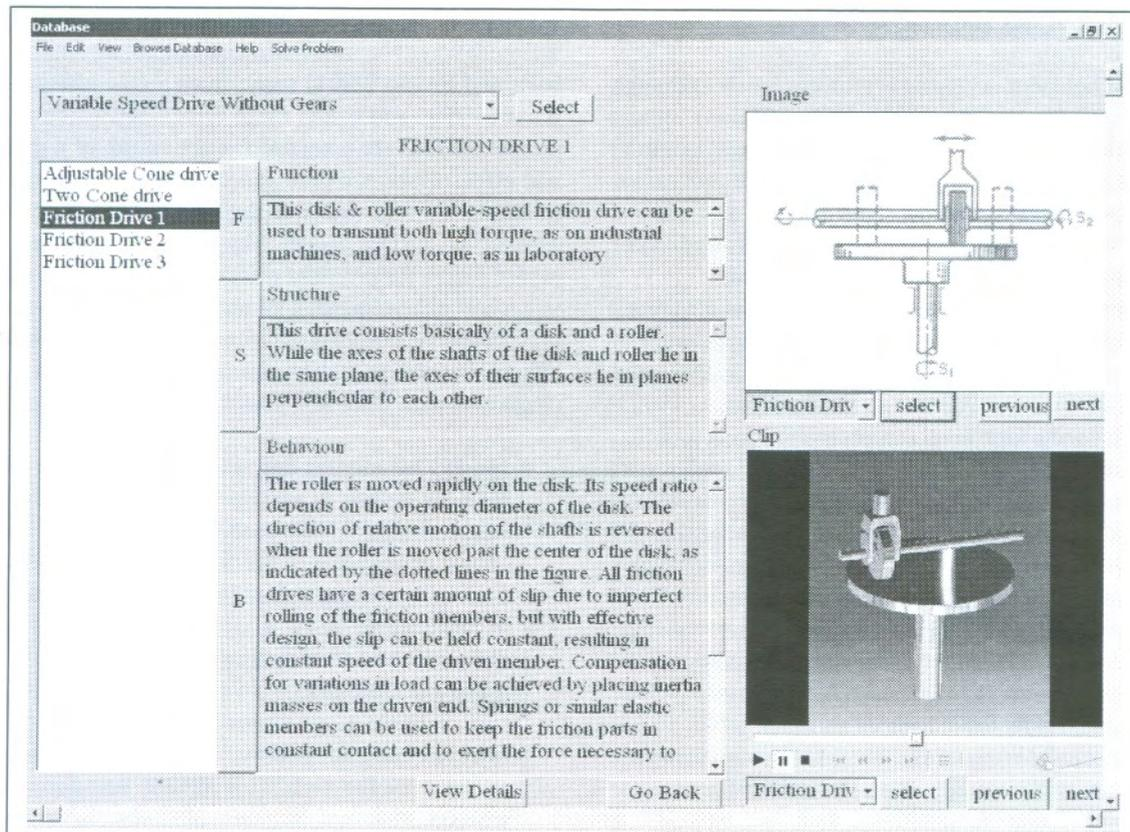

Fig. 2. A screen capture of an entry from the database of artificial systems.

richer causal description, suitable for the purposes of the researchers.

We therefore view function as the intended effect of a system (Chakrabarti & Bligh, 1993) and behavior as the link between function and structure defined at a given level. Thus, what is behavior is specific to the levels at which the function and structure of a device are defined.

Similarly, there are several views of what a structural description should be. FBS models generally assume that structure is the part-level composition of elements and interfaces of a device, whereas design methodology literature often defines it at several levels of abstraction. For instance, Pahl and Beitz (1988) define structure of an artifact at five different levels: functional structure, working principle (like organs later), concept, embodiment, and detail. Hubka (1976) defines structure of an artifact at four different levels: process, function, organ, and part; and Hansen and Andreasen (2002) refine these into three levels: transformation, organ, and part.

For the same reason for supporting multiple views of function and behavior, we believe that structure, in a richer behavioral representation, must also have the flexibility of being represented using multiple views.

From the existence and usefulness of multiple views of function, structure, and behavior, we feel that these views are but specific and limited aspects of a richer underlying causal description of behavior. What is problematic in many FBS models is the implicit equation of this rich causal description of the behavior of a system with a fixed, pre-defined division of this knowledge into function, behavior, and structure. With the exception of Andreasen's (1980) work in which behavior is viewed at multiple levels (although not integrated into a common causal description), others seem to implicitly assume this overall causal description to be synonymous to a specific FBS model. We see this causal description as separate from an FBS model, and view a given FBS model as a way of viewing particular portions of this description at particular levels of abstraction.

The works that influence our work the most are the theory of technical systems of Hubka (1976), the domain theory of Andreasen (1980), the FBS work of Umeda et al. (1996), and the metamodel work of Yoshioka and Tomiyama (1997). Hubka (1976) used a four-level representation for a product: a process level, a function level, an organ level, and a part level. Andreasen (1980) modified this into a three-level representation in his domain theory: transformation, organ, and structure. Umeda et al. (1996) developed a function-behavior-state model in which they use function as the top level, and define behavior using what they call physical phenomena (e.g., electricity flowing) and structural entities and relationships (e.g., conductors connected via wires). Although many of the building blocks used by these authors are essential for developing a rich, causal description of the functioning of an artifact in a given environment, these are not sufficient for producing such a description.

For instance, not all existing views of function, structure, and behavior are represented in any of the above models. In

particular, the distinction between the various semantically distinct representations of function (e.g., I/O and state change) remains unclear in the transformation level representation. Structural description is somewhat limited in Tomiyama's work, although it is richer in those of Hubka (1976) and Andreasen (1980). Behavioral representation is minimal in Andreasen (1980) and Hubka (1976), but it is richer in the work of Yoshioka and Tomiyama (1997) and Umeda et al. (1996). Organs are rather narrowly defined in Andreasen's (1980) work, not taking into account the characteristics of the context or environment in their definition, but they are not used in the FBS model of Umeda et al. (1996). What is also missing in these descriptions is the explicit use of physical effects and the link to state changes effected by virtue of the effects. As a result, these representations individually are less than adequate for providing a rich, behavior level explanation of an artifact or a natural system's functioning.

The concept of "organ" was first used by Hubka (1976). Andreasen (1980) used this idea in his domain theory, and Yoshioka and Tomiyama (1997) and Chakrabarti and Regno (2001) later used similar concepts in other contexts. The essence of an organ lies in specific aspects of an object that allow it to activate specific effects. Hubka (1976) and Andreasen (1980) came from an artifact modeling perspective, and called organs the active elements that create intended effects in a mechanical product. Tomiyama came from a qualitative modeling perspective, called these aspects individual models, and proposed that because of our understanding of different models, we idealize components in different ways (beams, links, control volume, etc.). Chakrabarti and Regno (2001) came from a side effects detection point of view and called these effect-activation properties, properties that are essential for activation of a given physical effect. Here, we prefer to call these organs as a tribute to Hubka (1976), who was the first to externalize this concept in an artifact model. We define organs as structural prerequisites for physical effects created by assembling the structural characteristics of and relationships between the system and its context/environment to activate an effect or effects, in order to make a change of state (which may be no change of state after all) possible. To summarize:

- Many FBS models define *a priori* what the functional level of device is and so forth. This is arbitrary and counterintuitive. We need to dissociate the underlying causal description of the functioning of a system from the subjective and partial FBS views on this description.
- We therefore need a richer, encompassing causal description of the functioning of a system. This should allow multiple FBS views to be taken on the description, in terms of multiple levels of granularity of structure and behavior and multiple aspects of the causality as intent or function. This should also allow multiple, existing views of function and behavior to be embedded and discernible within the description. Structure should be represented at different levels, and should

include properties of the artifact or system as well as relevant properties of its context or environment.

- Explanation should be rich enough to be provided using physical effects. We feel that the “organ” view must be included if this were to be achieved in a nonarbitrary fashion. This means that the representation must include both organs and physical effects as its elements.
- Our experience shows that what is considered input for one system is a state change for another. In other words, input and state change are views created by system boundaries. This interpretational aspect must be made explicit.

5.1. Behavioral description

The main challenge for the behavioral description has been that it must allow the function, behavior, and structure of a system to be linked to each other in a way common for both natural and artificial systems, and allow describing these at various levels of abstraction. Both function and behavior of a system are taken to be descriptions of what a system does, except that function is intentional and at a higher level of abstraction than its behavior, which can be taken as the way in which the function is achieved. Structure is described by the elements and interfaces of which the system and its immediate, interacting environment are made. At the core of behavior of a system are changes of the state of the system, and how these are brought about by the right contexts formed by the properties of the system and its environment, and inputs from these, in order to activate the physical effects necessary to effect the change of state. Seven elementary constructs are used.

1. *Parts*: A set of physical components and interfaces constituting the system and its environment of interaction.
2. *State*: The attributes and values of attributes that define the properties of a given system at a given instant of time during its operation.
3. *Organ*: The structural context necessary for a physical effect to be activated.
4. *Physical effect*: The laws of nature governing change.
5. *Input*: The energy, information, or material requirements for a physical effect to be activated; interpretation of energy/material parameters of a change of state in the context of an organ.
6. *Physical phenomenon*: A set of potential changes associated with a given physical effect for a given organ and inputs
7. *Action*: An abstract description or high level interpretation of a change of state, a changed state, or creation of an input.

The relationships between these constructs are as follows: *parts* are necessary for *creating organs*. Organs and *inputs* are necessary for *activation* of *physical effects*. Activation of physical effects is necessary for *creating physical phenomena* and changes of *state*, changes of state are *inter-*

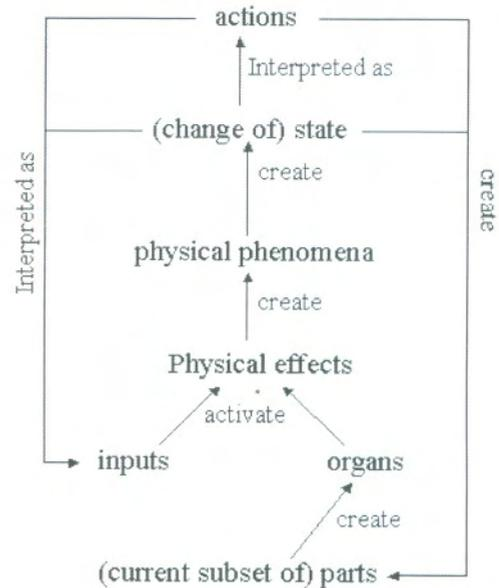

Fig. 3. The SAPPhIRE model of causality.

preted as actions or inputs, and *create* or *activate* parts. Essentially, there are three relationships: *activation, creation, and interpretation*.

The acronym for the causal description language is the SAPPhIRE model, which stands for State-Action-Part-Phenomenon-Input-oRgan-Effect (see Fig. 3). Using the constructs and relationships of this model, behavior of each system is described in the databases developed. For examples of how this language is used in representing functionality of systems, see Appendix A and Appendix B.

In our view, function is seen as specific, limited, intended aspects of the rich causal behavior of artifacts embedded in and in conjunction with the environment in which it operates, and could be seen as the following:

- state change;
- attained, final state;
- inputs;
- I/O transformation; and
- creation of the context for physical effects to appear, that is, organs, and so forth.

The distinct features of this representation are the following features:

1. The drivers of change are *physical phenomena/process*, which are change processes anticipated to take place in a given system as a result of activation of physical effects or principles that hold true in a particular context provided by some inputs and some organs: say “air going out of the space between the two surfaces” due to law of fluid motion “air moves from area of high to low pressure,”

2. *Actions* are high level (often verbal) descriptions of some change of state without stating how the state change is performed: for example, move object, rotate object, and so forth.
3. Inputs are energy, materials, or signals that flow through a system: such as providing *rotation* to a shaft, or temperature change in an enclosed space. These are abstractions of state changes that are used because of our interest in them. Organs are particular physical contexts necessary for a physical effect to be activated.
4. Certain aspects of a change of state are defined as *input*, such as pressure change under a lizard's foot (as an effect of its bending).
5. Parts of an object and/or its environment are described using a set of attributes of their components and interfaces. For instance, the part level structure of a lizard's foot has several components: boned structure covered with soft tissue using muscles that contract to actuate the bones in order to provide the stretching. Different aspects of the same part (and part of its various environments) can be used to create organs that provide the context for different physical effects to be activated.
6. Our representation uses actions, physical effects, physical phenomena, inputs, organs, and part-level structural descriptions as constructs for the representation. Umeda et al. (1996) use what we call actions, physical phenomena, and a part-level structural description in their representation, and not physical effects, organs, and inputs. Andreasen (1980) uses actions, organs, and part-level structural descriptions, and not physical effects, physical phenomena, and inputs.
7. Andreasen (1980) uses the concept of organ only when it is intentionally used, and the concept is restricted to properties of artifacts only, whereas we extend the concept of an organ to mean any composition of attributes, some of which may be from the environment, which is the necessary structural precondition for activating a physical effect.
8. We do not constrain structure to be defined at a single level, but allow the freedom for it to be interpreted at several levels, such as physical components and interfaces, a set of organs or a set of physical effects, so that depending on which of these is used as the "structural description" of the artifact (i.e., where we decide to stop decomposing the structure any further), its behavior (of how it achieves its function at any predefined level) can be explained.
9. We do not constrain function/behavior to be defined *a priori* in the model. All we provide is a rich description of causality between the above constructs. An FBS model is like a "panning" function at a given zoom level to see how intent connects to structure at that level.
10. We believe that being able to define inputs, actions and changes of state, and link them together as

interpretations/different level descriptions of one another, we get closer to resolving the issue of multiple representations of function and understand them as partial descriptions of the rich, causal behavior that they approximate in one way or another.

11. By insisting on detailing the causal description of entries to the level of physical effects, we attempt to reach a nonarbitrary degree of detail of behavioral explanation.

6. IMPLEMENTATION

The SAPPhIRE model of causality (Fig. 3) is used to represent the entries in the databases, and reasoning procedures are developed to help browse and search for entries that are (analogically) relevant for solving a design problem.

The concepts are implemented in software called IDEA-INSPIRE (2004), which can be used in two different modes:

1. *When a designer is ready to solve a well-defined problem.* In this case, the designer can directly define the problem using constructs, and use reasoning procedures of the software for automated search for solutions. There are several levels of problem description possible (see Section 6.2).
2. *When a designer is trying to solve a not so well-defined problem.* In this case, the designer can browse either of the databases and view related biological or artificial mechanisms, then get interested in some of these mechanisms, and may work on these selected mechanisms only, to use their ideas to solve the problem. Browsing may also help in understanding a problem better, as a designer will be exposed to a wider variety of related yet concrete solutions. In some cases, the designer may use mode 1 (above) and try out different combinations of the behavior language constructs until satisfactory solutions are obtained.

In each of these cases, the output from the software is a list of entries that match the constructs provided to the search engine to solve the problem. The block diagrams (Figs. 4 and 5) explain this process visually. The information provided is in the forms shown in Figures 1, 2, 6, and 7. Sections 6.1–6.3 describe how the entries are represented, how a problem is defined, and how search procedures work for finding relevant entries that could (analogically) solve a given design problem.

6.1. Representation of entries

Each entry in the databases is described, using the constructs of the SAPPhIRE model of causality (Fig. 3), in two forms: a human-understandable form (see Figs. 6 and 7 for examples), and a computer-understandable form (see Appendices A and B for examples). In the computer-understandable form, the content of each entry is divided into a list of actions, state, physical phenomena, inputs, physical effects,

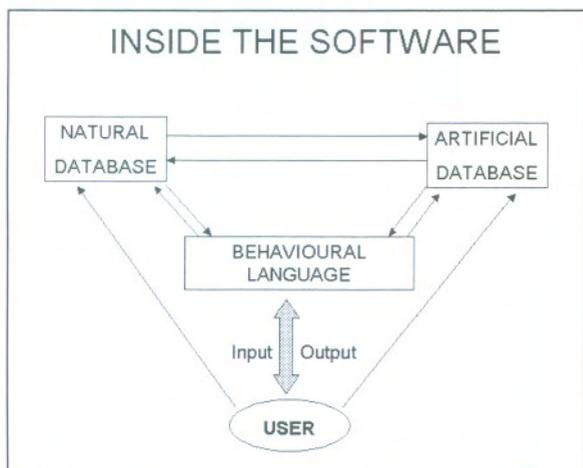

Fig. 4. A block diagram of the internal structure of IDEA-INSPIRE.

organs, and parts; links between various subsets of these together constitute the entry. Each linked subset is an abstract description of how an action is created as an interpretation of a set of state changes that are created by a set of physical phenomena that are formed using a set of organs that are formed by a set of parts and inputs that are interpretations of a change of state. For an example, see below the representation of a Venus flytrap (for full details, see Appendix A).

In the current database because the entries rarely have adverbs, we have represented adjective/adverb as adjectives only.

Actions are described using a list of verbs, nouns, and adjectives. For instance, the action of feeding is described

using “feed” as a verb and with no specific noun or adjective as qualifiers:

ACTION: { A1 \$ V < feed > A < > N < > \$ }

A state change is also described using a verb linked with a noun and/or an adjective. In this case, one such state change is “open trap,” which is described using the verb “open” and noun “trap” with no specific adjective:

STATE: { SS1 \$ V < open > A < > N < trap > \$ }

Physical phenomena are also expressed in terms of verbs, nouns, and adjectives. For instance, the physical phenomenon of “production of a chemical” is described using verb “produce” and noun “chemical” with no specific adjectives.

PHYPHENOMENON:

{ PP1 \$ V < produce > A < > N < chemical > \$ }

Physical effects are described using the name of the effect, for example, “Stimulus–Response effect.”

PHYEFFECT: { PE1 \$ Stimulus–Response effect \$ }

An input is represented using a verb, noun, and/or an adjective. For instance, an input “electrical signal” is described using no verb, the noun “signal,” and the adjective “electrical”:

INPUT: { I1 \$ V < > A < electrical > N < signal > \$ }

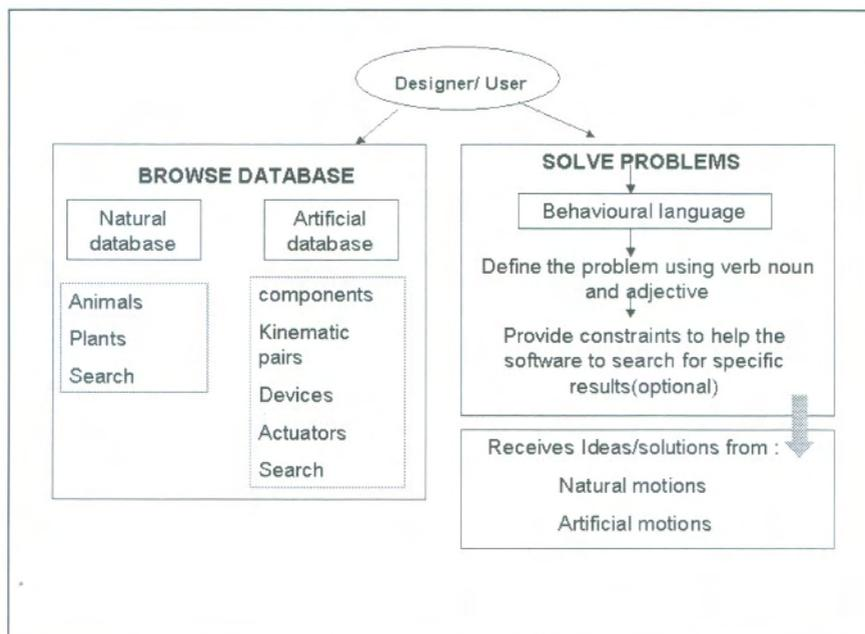

Fig. 5. A block diagram showing different options available for using IDEA-INSPIRE.

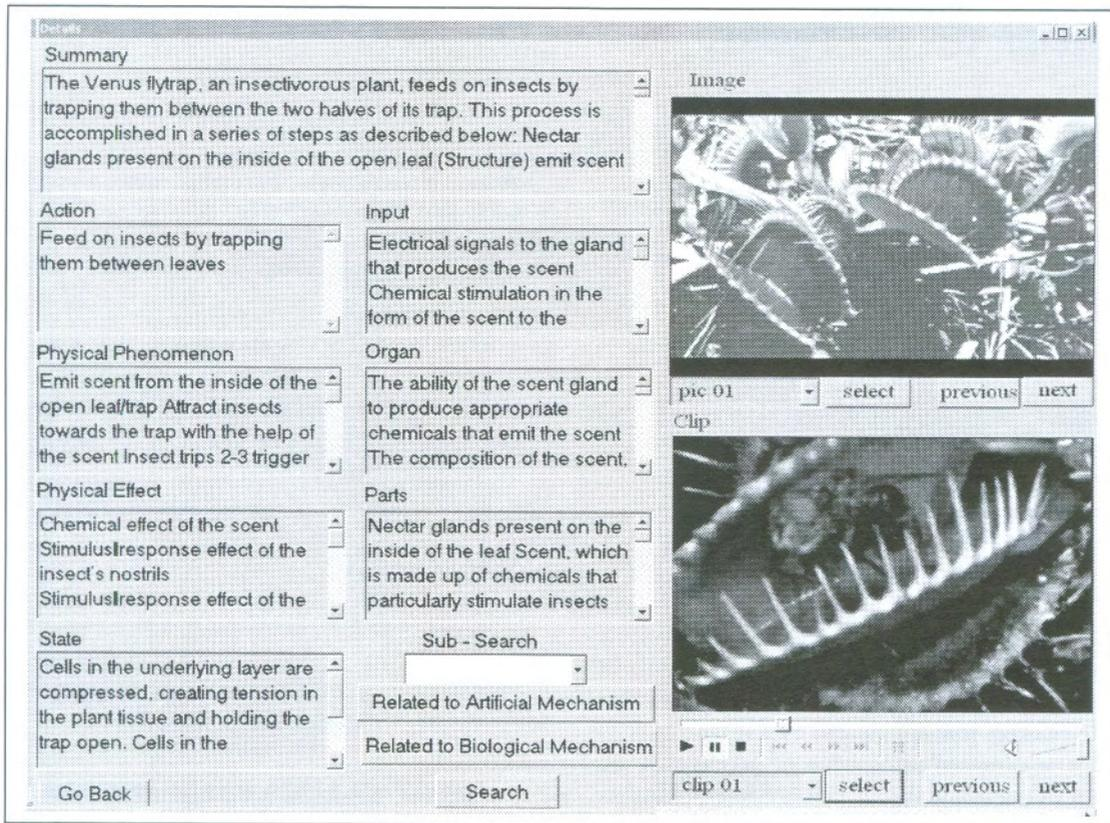

Fig. 6. A screen capture of an entry from the database of natural systems, showing the human-understandable constructs.

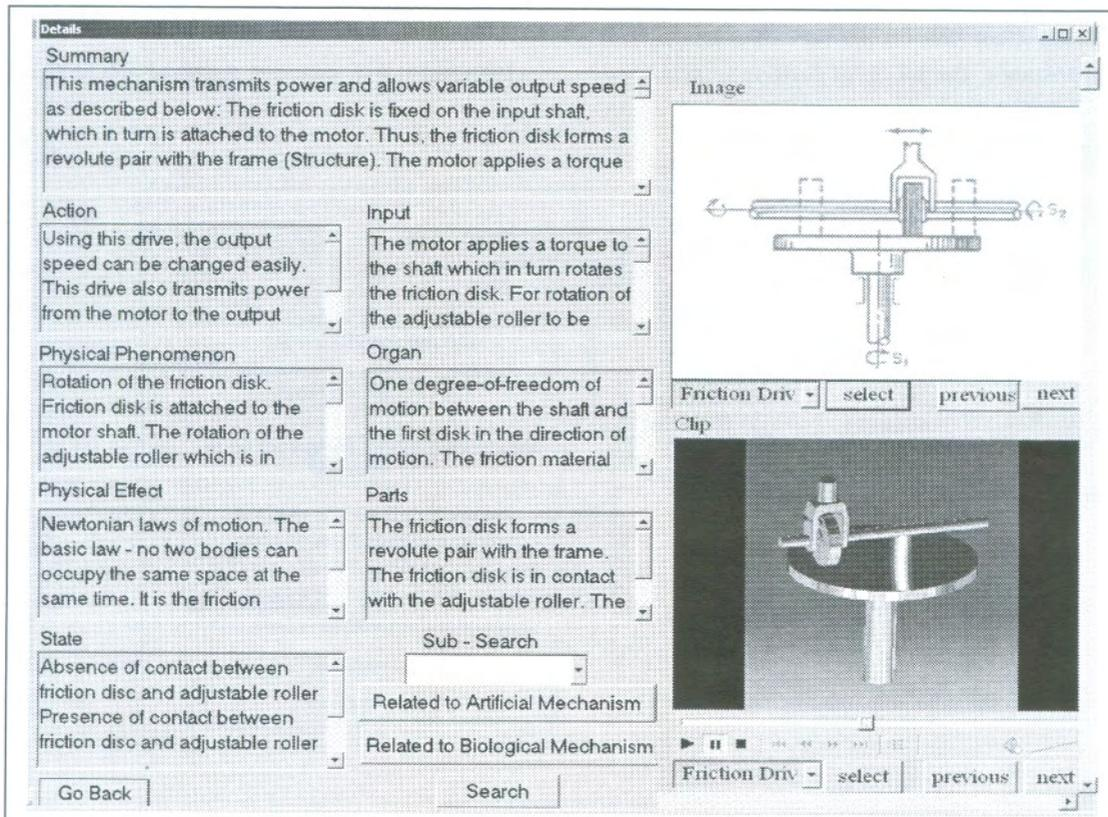

Fig. 7. A screen capture of an entry from the database of artificial systems, showing the human-understandable constructs.

An organ is currently described with the help of a phrase that describes the organ. In the example case, one such organ is “the ability of the scent gland of Venus flytrap to produce appropriate chemicals for scent emission”:

ORGAN: { O1 \$ The ability of the scent gland to produce
appropriate chemicals that emit the scent \$ }

Parts are defined as a list of components and interfaces and described using nouns and adjectives. In the example case, the part relevant is a “gland,” and is described using the noun “gland” only.

PARTS: { P1 \$ V <> A <> N < gland > \$ }

The links between these individual fragments of knowledge are represented using ordered lists. For instance, the above knowledge fragments are linked together by linking the action (identifier) with physical phenomenon with the physical effect with the input with the state change with the organ with the part, and is represented as the following link:

LINK: A1-SS1-PP1-PE1-I1-O1-P1

In the human-understandable form of the entries, these links are expanded into human-understandable sentences. For instance, the above link in human-understandable form has the following content (see Fig. 6).

The Venus flytrap feeds on insects by trapping them between the two halves of its trap (action). Part of this can be interpreted as a change of state from a closed trap to an open one (state). Nectar glands present on the inside of the open leaf (part) emit scent (physical phenomenon). This is due to the triggering of the glands by electrical signals (input), which activates the stimulus–response effect (physical effect) and requires that the glands (organ) produce appropriate chemicals that emit the scent. For complete detail of this entry at this level, see Appendix A. A similar entry at the same level from the artificial database is shown in Figure 7; for more details about this entry, see Appendix B.

6.2. Representation of a problem

A design problem can be described directly or indirectly. A direct description of a problem is the action required to be fulfilled, and the search task is to retrieve all entries that have this or its synonymous actions. The indirect description of the problem is the search for entries that have some constructs linked to the action desired, for example, entries that have the state changes associated with the desired action. Currently, the indirect description is not implemented, and the following example illustrates two possible ways in which a problem can be described directly.

An action is described using a verb–noun–adjective/adverb triplet. For instance, for an example problem: *Design an aid that can enable people with disabled upper limbs to*

eat food, a designer could describe the action required in many ways using different sets of verbs, nouns, and adjectives. Some examples of alternatives are given below:

1. V = feed, N = solid, A = slow (put solid food in the mouth).
2. V = supply, N = mixture, A = smooth (the designer can regard the food as a mix of several materials, hence, the use of the word “mixture”)
3. V = consume, N = solid, A = slow.
4. V = take, N = solid, A = (nil).
Alternatively, the problem can be decomposed into a few subproblems and solutions to these can be searched for. Some of the possible combinations follow.
5. (V = hold, N = solid, A = quick) + (V = move, N = solid, A = slow) + (V = push, N = solid, A = slow) (in this case, the designer may be thinking of designing a device that will first take the goods in a container, move close to the mouth, and transfer it to the mouth).
6. (V = get, N = solid, A = slow) + (V = swallow, N = solid, A = slow).

6.3. Reasoning

The goal of the search strategies is to support analogical reasoning at multiple levels of abstraction. Using these strategies, a designer should be able to simply browse the entries for random stimulation, or systematically search through them with specific purposes.

The IDEA-INSPIRE software has a graphical user interface that allows either browsing of entries by categories or forming searches of various complexity. When a designer gives a problem as action described using a verb, noun, and adjective (VNA), the program takes these as “input” variables and search the computer-understandable form of the entries (Appendix A) for these variables. In each entry, Actions are represented by VNA, and these are matched with the selected variables. If a direct match with the variables is not found, it would search for synonyms of each variable in the entries and give a corresponding weight as explained in Section 6.3.1. These matched entries are sorted in a descending order of importance. The potential for an entry to have various degrees of matching with the input, along with its potential for inspiring new solutions, give rise to solutions having three different types:

1. Exact solutions: when all the constructs in an entry match with that of the given inputs, and a designer accepts this as it is as a potential solution to the problem.
2. Partial solution: when some of constructs in an entry match the given inputs, and a designer accepts this as it is as a potential partial solution to the problem.
3. Inspirational solution: when an entry with an exact or partial match with the given inputs triggers a designer to generate a new solution.

There are two strategies of analogical reasoning that are employed in the search process where a specific problem is defined by the designer:

- specification translation and
- jumping between the various behavioral levels.

These are explained in the following two subsections.

6.3.1. Translation of design input into analogical descriptions

This strategy should help develop analogical descriptions of the intended behavior used by a designer. For instance, if the specific intention is to pump oil from the ground, solutions for moving liquid, or lifting material may be potentially useful as insights for solutions to the problem.

The description of the mechanism looked for, its intended behavior, or constraints can be provided by a designer in terms of VNA. To implement the “translation” of this input into analogical descriptions, clusters of equivalent words (as synonyms and antonyms) have been developed. Clustering of words is carried out beforehand for nouns, verbs, and adjectives and stored in a database for use during translation. A *verb cluster* is divided into *generic verbs* and *specific verbs*. The clustering process is shown in Appendix C.

The demand (among VNA) selected by the user has a given higher weight. The weights of 32, 16, and 8 are given for a direct match of VNA and 4, 2, and 1 for a synonym match, respectively. The weight divided by the maximum weight [if the user selected VNA in this case ($36 + 16 + 8 = 56$)] multiplied by 100 gives the weight of the given entry. The above numbers have been selected after many trials and research, so that the following order of importance is achieved in terms of a numerical value. The main aim of coding with these typical numbers is to make a distinction among the combinations of many behavioral level constructs, internally. For instance, in the case of search for actions, more importance is given to verbs than to nouns, and more importance is given to nouns than adjectives. The highest weight is given to a direct match of VNA (provided by the designer). The order of importance is listed below:

Verb, Noun, Adjective ($32 + 16 + 8 = 56$), therefore weight = $56/56 \times 100 = 100\%$

Verb, Noun, Adjective (S) ($32 + 16 + 1 = 49$), therefore weight = $49/56 \times 100 = 87.5\%$; similarly, others have been assigned a weight.

Verb, Noun, Adjective (No) ($32 + 16 + 0 = 48$) weight = 85.7%

Verb, Noun (S), Adjective ($32 + 2 + 8 = 42$) weight = 75%

Verb, Noun (No), Adjective ($32 + 0 + 8 = 40$) weight = 71.4%

Verb, Noun (S), Adjective (S) ($32 + 2 + 1 = 35$) weight = 62.5%

Verb, Noun (S), Adjective (No) ($32 + 2 + 0 = 34$) weight = 60.7%

Verb, Noun (No), Adjective (S) ($32 + 0 + 1 = 33$) weight = 58.9%

Verb, Noun (No), Adjective (No) ($32 + 0 + 0 = 32$) weight = 57.1%

Verb (S), Noun, Adjective ($4 + 16 + 8 = 28$) weight = 50%

Verb (S), Noun, Adjective (S) ($4 + 16 + 1 = 21$) weight = 37.5%

Verb (S), Noun (S), Adjective ($4 + 2 + 8 = 14$) weight = 25%

Verb (S), Noun (S), Adjective (S) ($4 + 2 + 1 = 7$) weight = 12.5%

Verb (S), Noun (S), Adjective (No) ($4 + 2 + 0 = 6$) weight = 10.7%

Verb (S), Noun (No), Adjective (S) ($4 + 0 + 1 = 5$) weight = 8.9%

Verb (S), Noun (No), Adjective(No) ($4 + 0 + 0 = 4$) weight = 7.14%

where S is Synonym and No is No Match.

6.3.2. Searching entries having similar characteristics

Because each entry is a linked network of actions, organs, inputs, effects, phenomena, and parts, analogical solutions can be reached if it is possible to search for, say, entries that share the same principles in the entries that fulfill the required actions, or entries that have analogical parts to those that have the required intended action. For search of these kinds, one needs to be able to construct complex search queries with multiple, intermediate, and final search points of specified types and with specified input types and values. This can be achieved by a multiple search with the following form:

For a given input type, find all output of given type for all intermediate outputs of given types. For instance, one such query is: for a given action (input), find all entries (output) that provide actions (intermediate output type) that use the same effects (intermediate output type) as are used by the entries that provide the input action:

Given action → effects used → actions → entries

Such complex search problems are likely to help “discover” solutions that are more difficult to immediately associate with the design problem (e.g., the input action) at hand and yet are analogically relevant as potential ideas for solving the problem. Currently, implementation of this search strategy in the IDEA-INSPIRE software is under progress (Fig. 8).

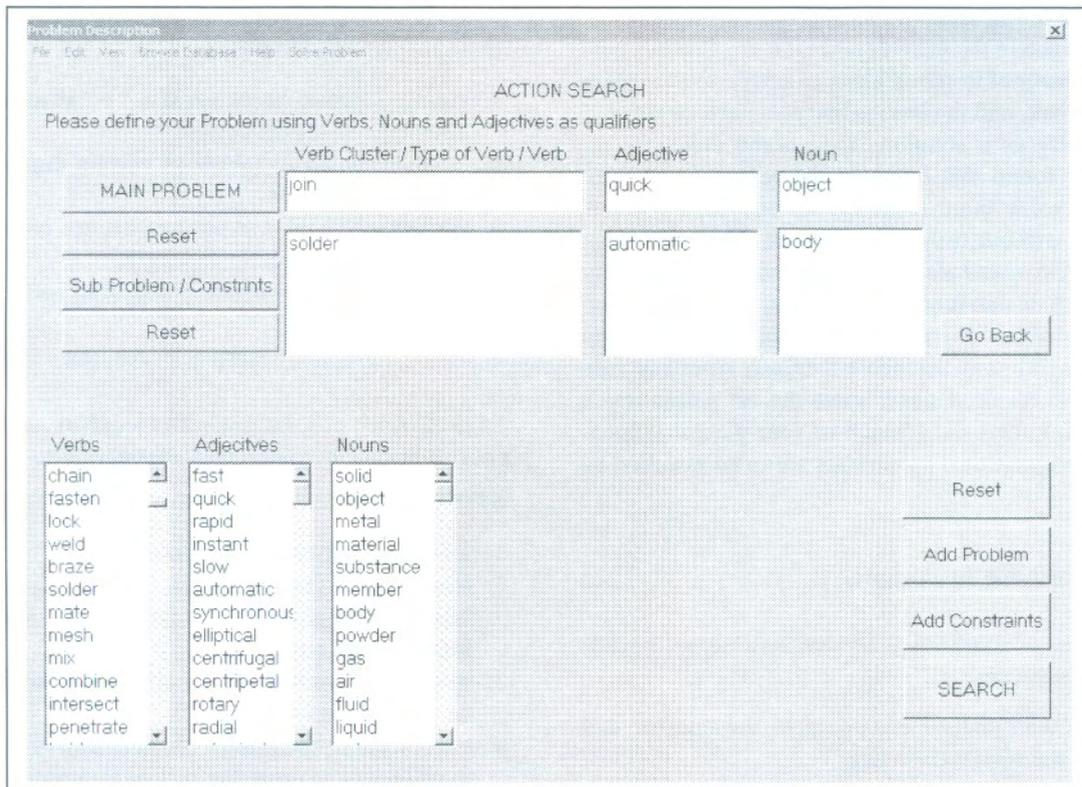

Fig. 8. A screen capture of the graphical user interface of the software for problem solving.

7. EXAMPLE

To understand how the IDEA-INSPIRE software could help a designer solve a design problem by inspiring generation of new ideas, let us take the example problem used in Section 6.1: *Design an aid for enabling eating for people whose upper limbs are disabled*. In this case, a designer could describe the problem in many ways: using different sets of VNA. In this case the search task is defined as that of finding all entries that have the design problem as one of their actions.

Let us look at two alternative representations of the problem:

Case 1. V = feed, N = solid, A = slow (put solid food in the mouth)

Case 5. (V = hold, N = solid, A = quick) + (V = move, N = solid, A = slow) + (V = push, N = solid, A = slow).

The entries retrieved by the software for these cases are as follows.

Case 1. List of some of the entries found by the software: aardvark, barracuda, duck, clam defence, pitcher plant, and so forth.

Case 5. List of some of the entries found by the software:

Subcase 1. (V = hold, N = solid, A = quick); reciprocating lever gripper, rack and pinion gripper, hydraulic gripper.

Subcase 2. (V = move, N = solid, A = slow); camel moving, millipede, baboon, crab walking, transport mechanisms, simple belt drives, and so forth

Subcase 3. (V = push, N = solid, A = slowly): currently, no entries are found for this subproblem.

Depending upon a designer's interest, various details of an entry could be explored. The problem may have to be redefined several times, using different VNA words, until satisfactory solutions are found.

8. PRELIMINARY EVALUATION

To evaluate the general usefulness of the software for inspiring creative solutions in designers, three designers were requested to solve individually two problems of their choice from a pool of problems given without using the IDEA-INSPIRE software and then by using the software. All three designers have an undergraduate degree in engineering and have formal product design training, with designers 2 and 3 having more than 2 years of professional experience in

design. The idea was to see if the intervention made a substantial difference in the number and kind of solutions generated. The number of inspiring ideas, triggered by the entries from the software, and the entries (in the database) that can be used directly as a solution, were noted down by the designers. We found that by using the software, all three designers got some more ideas for solving each problem than they did without using the software. The results are summarized below, and elaborated for one of the problem-solving cases. A design problem chosen by all three designers is *design problem 1*: design a mechanism for an eraser manufacturing company that can cut erasers from a rectangular block into required sizes, move the cut pieces into a funnel, and pack them in a bunch of four pieces. Dimensional and configurational constraints are to be assumed by the designer.

8.1. Problem solving by designer 1

STEP 1. A list of solutions generated by designer 1 without the aid of software:

1. cutting: cutter shaped according to the number and shape of the required erasers;
2. laser cutting;
3. punching;
4. high-speed water jet cutting;
5. heated tungsten wire cutting;
6. chemical cutting;
7. material removal: use of a sharpener kind of arrangement to remove excess material from a block of rubber; and
8. extrusion: piston-cylinder arrangement to get the eraser through a template.

STEP 2. A list of solutions with the aid of software:

1. modified transport mechanism: parts of the mechanism that transport objects are modified into cutters, which cut a block of rubber into individual pieces of rubber and push them ahead;
2. sorting mechanism: implemented directly for sorting and packing;
3. saber saw cutting;
4. plasma cutting;
5. four-bar cutting; and
6. parallel/vertical cutting.

STEP 3. A list of solutions with inspiration from software: none.

8.2. Problem solving by designer 2

Designer 2 divided the given problem into several partial problems and attempted to solve each problem individually. The solutions generated are as follows.

STEP 1. A list of solutions generated by the designer without the aid of software:

1. cutting a rubber block using a "+" shaped cutter and also with a vertical cutter;
2. cutting a block of rubber of certain dimension vertically in four pieces;
3. cutting with a die that has an attached container at the bottom, for automatic packaging;
4. cutting the rubber block in a kind of rolling machine; and
5. cut into piece and warp it, according to the weight.

STEP 2. A list of solutions with the aid of software: some partial solutions, but none very interesting to the designer.

STEP 3. A list of solutions with inspiration from software:

1. using a spiral cutting process;
2. frog: animal characteristics of jumping. Rubber can be used in large scale and rebounded . . . (according to jumping and catching);
3. insect trap (Venus flytrap): this same mechanism can be used to cut billets;
4. pitcher plant: the rubber block is thrown on a hopper that vibrates, cutting the rubber into pieces (timing is crucial);
5. duck movement: similar way as the duck moves the rubber block, is cut by micromember mechanism;
6. sprocket and chain: the sprocket kind of cut wheel edge can be directly used on . . . to cut the block; and
7. Cardan mechanism-4: for pick and place of cut rubber pieces.

8.3. Problem solving by designer 3

STEP 1. A list of solutions generated by the designer without the aid of software:

1. side cutter,
2. mechanism followed in biscuit manufacturing, and
3. laser cutting.

STEP 2. A list of solutions with the aid of software:

Implemented directly from the entries:

1. four-bar cutter,
2. parallel cutter, and
3. sorting mechanism.

Modified into the cutting mechanism:

1. reciprocating lever gripper,
2. rack and pinion gripper, and
3. lift door closing mechanism.

STEP 3. A list of solutions with inspiration from software:

Table 1. Two descriptions of the same problem and search results with weights

Verb	Noun	Adjective	Results (Weight)
Divide	Uniform	Length	Saber saw (7.14)
			Plasma cutter (7.14)
			Four-bar cutter (7.14)
Cut	Straight	Part	Saber saw (60.71)
			Plasma cutter (60.71)
			Four-bar cutter (60.71)

1. autostop mechanism-1: using a rope that is attached with cutters;
2. autostop mechanism-4: cutter of four different sizes, and the rubber block is passed through;
3. barnacle: cutting blades are kept in series and the rubber block is passed perpendicular to it; and
4. sunflower: cutters are kept like a mesh and are punched into the rubber block.

Table 1, shows, in one of these problem cases, the two descriptions used by the designers to describe the same problem using separate sets of VNA, and the entries found against each description. Note that the entries found are the same, and the difference is in the weights of these entries. Because in the second description, “cut” is used as the verb that has a direct match with the entries, they have a much higher weight than those in the first description that finds these entries only by using synonyms (Table 1).

8.5. Overall statistics of solutions generated in the trials

Tables 2–4 give an overview of the number and percentage of design solutions generated by the three designers for their design problems with and without aid from the software. Even though these are not intended to be taken as quantitative proof of the efficacy of the software as only six experiments are conducted using four problems (one prob-

Table 2. Overview of the number and percentage of design solutions generated by designer 1

Designer 1				
	Solutions Without Software		Solutions With Software	
			Direct Solutions	Inspired Solutions
Problem 1	8 (8/9 × 100)	88.8%	—	1 (11.2%)
Problem 2	9 (60%)		6 (40%)	—

Table 3. Overview of the number and percentage of design solutions generated by designer 2

Designer 2			
	Solutions Without Software	Solutions With Software	
		Direct Solutions	Inspired Solutions
Problem 1	5 (41.7%)	—	7 (58.3%)
Problem 2	8 (72.7%)	—	3 (27.3%)

lem is common among the six chosen) and three designers, they are indicative of the kind of impact such software could have on design creativity.

What appears to be promising is that the software, with a limited number of data entries accounts for an average of about 47% of all the ideas generated. This indicates that such an aid could be useful to designers in generating and inspiring new ideas, especially when they have run out of ideas. During the design experiment, one designer commented that the software could also be very useful at a point when a designer might be willing to learn about a certain process/product in depth, in order to scrutinize whether the entry could be used as a possible solution or not (Fig. 9). One question that arises is: how idea inspiration takes place? What aspect of the knowledge retrieved triggers ideation? Work is in progress in developing understanding in this regard.

9. SUMMARY AND CONCLUSIONS

With the aim of initiating work in systematic biomimetics and developing an integrated approach for systematic idea generation in product design using inspirations from natural as well as artificial systems, a new generic model for representing causality of natural and artificial systems has been developed, and implemented in a piece of software for automated, analogical search of relevant ideas from data-

Table 4. Overview of the number and percentage of design solutions generated by designer 3

Designer 3			
	Solutions Without Software	Solutions With Software	
		Direct Solutions	Inspired Solutions
Problem 1	3 (23.1%)	6 (46.2%)	4 (30.7%)
Problem 2	3 (33.3%)	—	6 (66.7%)

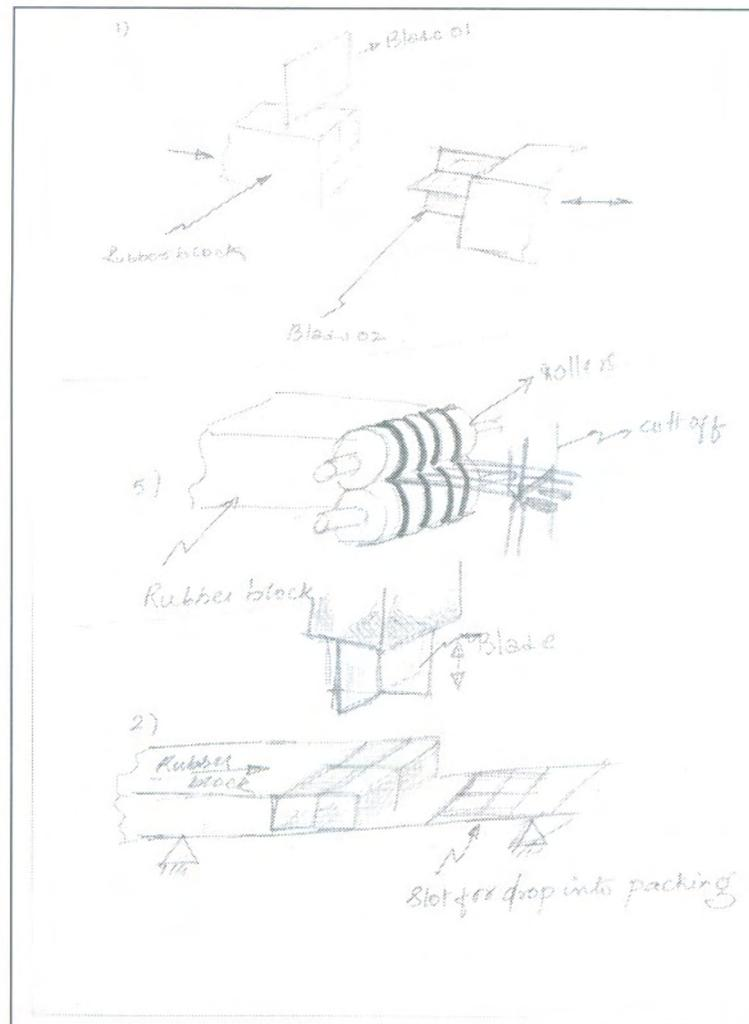

Fig. 9. Sketches done by designer 2 during the exercise.

bases of systems, annotated with the constructs of the model, to solve a given problem. Preliminary experiments at validating the software indicate substantial potential for the approach, although further development is in progress in extending the number of entries in the databases, extending strategies for more complex searches, understanding the process of triggering ideation, and in evaluating the software for more cases using more designers.

ACKNOWLEDGMENTS

A major part of the work described in this paper is the outcome of a project on biomimetics, which was funded by the Indian Space Research Organization (ISRO), Bangalore, India. Development and testing were carried out in-house in the Innovation, Design Study and Sustainability Laboratory (IDeAS lab), Centre for Product Design and Manufacturing, Indian Institute of Science, Bangalore. The authors acknowledge help from B.P. Pramod, Rohit Parangath, S. Sankesh, and V. Sekhar Chowdary in various phases

of development of the software, and from N. Bhargava, S. Shiva Kumar, and Santosh Jagtap in pilot testing of the software.

REFERENCES

- Andreasen, M.M. (1980). *Syntesemetoder pa systemgrundlag*. PhD Thesis. Lund Technical University, Lund, Sweden.
- Bhatta, S., Goel, A., & Prabhakar, S. (1994). Innovation in analogical design: A model-based approach. *Proc. AI in Design*, pp. 57–74. Dordrecht: Kluwer Academic.
- Chakrabarti, A. (2001). Towards hybrid methods for synthesis. *International Conference on Engineering Design (ICED 01)*, pp. 379–386, Glasgow.
- Chakrabarti, A., & Blessing, L. (1996). Representing functionality in design. *Artificial Intelligence for Engineering Design, Analysis and Manufacturing* 10(4), 251–253.
- Chakrabarti, A., & Bligh, T.P. (1993). Towards a theory for functional reasoning. *Proc. Int. Conf. Engineering Design (ICED 93)*, Vol. 1, pp. 1–8, The Hague.
- Chakrabarti, A., & Bligh, T.P. (2001). A scheme for functional reasoning in conceptual design. *Design Studies* 22(6), 493–517.
- Chakrabarti, A., & Regno, R. (2001). A new approach to structure sharing. *Int. Conf. Engineering Design (ICED 01)*, pp. 155–162, Glasgow.

- Chakrabarti, A., Johnson, A.L., & Kiriya, T. (1997). An Approach to automated synthesis of solution principles for micro-sensor designs. *Proc. Int. Conf. Engineering Design*, Vol. 2, pp. 125–128, Tampere.
- Chandrasekaran, B. (1994). Functional representation and causal processes. In *Advances in Computers* (Yovits, M.C., Ed.), pp. 73–143. New York: Academic.
- Deng, Y.M. (2002). Function and behavior representation in conceptual mechanical design. *Artificial Intelligence for Engineering Design, Analysis and Manufacturing* 16(4), 343–362.
- French, M.J. (1998). Invention and evolution. *Design in Nature and Engineering* New York: Cambridge University Press.
- Goel, A.K. (1997). Design, analogy and creativity. *IEEE Expert: Intelligent Systems and Their Applications* 12(3), 62–70.
- Gordon, W.J.J. (1961). *Synthesis: The Development of Creative Capacity*. New York: Harper & Row.
- Hansen, C.T., & Andreasen, M.M. (2002). Two approaches to synthesis based on domain theory. In *Engineering Design Synthesis* (Chakrabarti, A., Ed.), pp. 93–108. New York: Springer-Verlag.
- Hubka, V. (1976). *Theorie der Konstruktionsprozesse*. Berlin: Springer-Verlag.
- IDEA-INSPIRE. (2004). *Idea-Inspire User's Manual*. Bangalore, India: Centre for Product Design and Manufacturing, Indian Institute of Science.
- Kletke, M.G., Mackay, J.M., Barr, S.H., & Jones, B. (2001). Creativity in the organization: the role of individual creative problem solving and computer support. *International Journal of Human-Computer Studies* 55, 217–237.
- MacCrimmon, K.R., & Wagner, C. (1994). Stimulating ideas through creative softwares. *Management Science* 40, 1514–1532.
- Murakami, T., & Nakajima, N. (1997). Mechanism concept retrieval using configuration space. *Research in Engineering Design* 9, 9–11.
- Pahl, G., & Beitz, W. (1988). *Engineering Design: A Systematic Approach*. Berlin: Springer-Verlag.
- Qian, L., & Gero, J.S. (1996). Function-behavior-structure paths and their role in analogy-based design. *Artificial Intelligence for Engineering Design, Analysis and Manufacturing* 10(3), 289–312.
- Umeda, Y., Ishii, M., Yoshioka, M., Shimomura, Y., & Tomiyama, T. (1996). Supporting conceptual design based on the function-behavior-state modeler. *Artificial Intelligence for Engineering Design, Analysis and Manufacturing* 10(3), 275–288.
- Vogel, S. (1998). *Car's Paws and Catapults: Mechanical Worlds of Nature and People*. New York: W.W. Norton.
- Watson, D.L. (1989). Enhancing creative productivity with the Fisher associated lists. *The Journal of Creative Behavior* 23, 51–58.
- Yoshioka, M., & Tomiyama, T. (1997). Pluggable metamodel mechanism: A framework of an integrated design object modelling environment. In *Computer Aided Conceptual Design '97, Proc. 1997 Lancaster Int. Workshop on Engineering Design CAD '97* (Bradshaw, A. & Counsell, J., Eds.), pp. 57–70. Lancaster, UK: Lancaster University.

APPENDIX A: VENUS FLYTRAP EXAMPLE FROM NATURAL DATABASE

A.1. Function

The Venus flytrap is an insectivorous plant that usually grows in areas where the fertility of the soil is poor. Thus, it supplements the nutrients it absorbs from the soil by consuming insects.

A.2. Structure

The leaf blade is bivalved, convex, but not hinged per se, and bears up to six sensitive hairs per half-leaf. The two halves of the trap look like a large, opened butter bean with long spines around the edges. After about 10–12 closures (partial or complete), the traps lose the ability to capture anything. The leaves remain spread wide open, and instead of going through the ritual of attracting insects and eating them, the former trap devotes its energy to the process of photosynthesis for the remainder of its life span, which is usually around 2–3 months. This way, if a trap is repeatedly

stimulated by nonedible objects, the plant can recoup some of the energy and adenosine triphosphate (ATP) lost due to opening and closing by focusing solely on photosynthesis.

A.3. Behavior

A.3.1. Trapping mechanism

When prey is caught. The scent emitted by chemicals secreted from nectar glands on the inside of the open leaf attracts flies and other insects. An insect must trip two or three sensitive trigger hairs suddenly, closing the leaf faster than the insect can escape.

An insect caught inside the partially closed trap will continue to thrash about in an attempt to escape. It is guaranteed that at least one (if not all) of the trigger hairs will be tweaked by the insect's movement. This serves as a signal to close the trap entirely. It takes about 1/30 of a second for the leaves to snap shut (in full sunlight); cloudy conditions or low temperatures slow the reaction time.

The lobe manufactures antiseptic and digestive juices. This keeps the insect from decaying over the few days it is in the trap, and purifies prey that is captured. To make sure that the insects are contained within the trap, the edges of the leaves have fingerlike cilia that lace together when the leaves press shut. The cilia are used to latch the trap shut. Digestion of an insect requires 3 to 5 days.

No prey caught. If no prey is caught (i.e., a twig or stone is caught), there is no stimulation of the hair. The trap stays in its partially shut state until tension can be reestablished in the leaves of the trap. This process takes about 12 h, at which point the leaves spread apart again. The unwanted object either falls out as the leaves reopen or is blown out by the wind.

Small prey caught. It is thought that the trap stays open for a few seconds to allow very small insects to escape, because they would not provide enough food. The clip shows the opening and closing mechanism that the plant adopts to catch its oblivious prey.

Working. Scientists theorize that the lobes move from some type of fluid pressure activated by an actual electrical current that runs through each lobe. The prevailing hypothesis of the day is that cells in an inner layer of the leaf are very compressed; this creates tension in the plant tissue that holds the trap open. Mechanical movement of the trigger hairs puts into motion ATP-driven changes in water pressure within these cells. The cells are driven to expand by the increasing water pressure, and the trap closes as the plant tissue relaxes.

A.4. Human-understandable form for Venus flytrap example

The Venus flytrap, an insectivorous plant, feeds on insects by trapping them between the two halves of its trap. This can also be interpreted as the following state changes: the insect is outside the trap; the halves of the trap open; the insect is inside the trap; the halves of the trap closed; and the insect disintegrated into basic chemicals. This process is accomplished in a series of steps as described below.

Nectar glands present on the inside of the open leaf (part) secrete chemicals that emit scent (physical phenomenon). This is due to the triggering of the glands by electrical signals (input), which activates the stimulus-response effect (physical effect) and requires

that the glands (organ) produce appropriate chemicals that emit the scent.

The scent that is emitted (part) attracts insects toward the trap (physical phenomenon). This is due to the stimulation of the insect's nostrils by the chemicals present in the scent (input), which activates the stimulus–response effect (physical effect) and requires that the composition of the scent is such that it is capable of stimulating the insect's nostrils (organ).

Each lobe of the trap consists up to six touch-sensitive hair (part). Two to three hairs are triggered suddenly (physical phenomenon) due to the movements of the insect sitting on the trap (input), which activates the stimulus–response effect (physical effect) and requires that the hair be able to convert movements into ATP-driven changes in the water pressure within cells beneath the trap (organ).

The trap consists of a bivalved, convex, leaf blade that is not hinged at its center, under which is a layer of fluid-filled cells (part). The trap closes partially (physical phenomenon) due to ATP-driven increase in water pressure within the cells (input). This activates the lever effect of the valves of the trap parts (physical effect) and requires that the trap close faster than the insect can escape (organ).

At least one of the six trigger hair (part) is tweaked (physical phenomenon) due to the movement of the trapped insect (input). This activates the stimulus–response effect (physical effect), and requires that the hair be able to convert movements into ATP-driven changes in the water pressure within cells beneath the trap (organ).

The edges of the leaf/trap have fingerlike cilia (part). These lace together and latch the trap shut (physical phenomenon). This is due to further increase in water pressure in the inner layer of cells (input), which activates the stimulus–response effect (physical effect) and requires that the direct link between the change in water pressure within the cells and closing/opening of the trap (organ).

Glands that produce antiseptic and digestive juices exist on the inner part of the leaf (part). These juices are secreted (physical phenomenon) due to the electrical triggering of the glands (input), which activates the stimulus–response effect (physical effect), and requires that the glands be able to produce these juices as and when triggered (organ).

The antiseptic secreted by the gland (part) purifies the insect and keeps it from decaying (physical phenomenon). This is due to the reaction of chemicals (input), which activates the chemical reaction effect (physical effect) and requires that the composition of the antiseptic be appropriate (organ).

The digestive juice secreted by the gland (part) digests the insect (physical phenomenon). This is due to the reaction of chemicals (input), which activates the chemical reaction effect (physical effect) and requires that the composition of the digestive juice be appropriate (organ).

Note: the organs, given the part of information available, cannot be more elaborate than this at present. With better understanding available, this will be made more detailed.

A.4.1. Action

- Feed on insects by trapping them between leaves.

A.4.2. State

- Insect, which is the Venus flytrap's prospective prey, is freely moving outside the trap.

- Cells in the underlying layer are compressed, creating tension in the plant tissue and holding the trap open.
- The insect has been trapped within the two halves of the flytrap and is lying motionless.
- Cells in the underlying layer are expanded and relax the plant tissues, resulting in a closed trap.
- The insect has been disintegrated into basic chemicals because of the action of digestive juices.

A.4.3. Physical phenomenon

- Emit a scent by secreting chemicals from glands on the inside of the open leaf/trap.
- Attract insects toward the trap with the help of the scent.
- Insect trips two to three trigger hairs present on the leaf suddenly.
- Close trap partially.
- Insect tweaks hair while trying to escape.
- Close trap entirely, thus trapping the insect.
- Secrete digestive and antiseptic juices.
- Prevent the insect from decaying and also purify it with the help of the antiseptic juice.
- Digest the insect by breaking it down into basic chemicals with the help of the digestive juice.

A.4.4. Physical effects

- Stimulus–response effect of the glands that produce scent-emitting chemicals.
- Stimulus–response effect of the insect's nostrils.
- Stimulus–response effect of the trigger hair.
- Lever effect of the two halves of the trap.
- Stimulus–response effect of the gland that produces antiseptic and digestive juices.
- Chemical reaction effect of the antiseptic.
- Chemical reaction effect of the digestive juice.

A.4.5. Input

- Electrical signals to the gland that produces the chemicals responsible for the scent.
- Chemical stimulation in the form of the scent to the nostrils of the insect.
- Physical stimulation in the form of movement of trigger hairs.
- Increase in fluid pressure in the inner layer of cells.
- Electrical signals to the gland that produces the antiseptic and digestive juices.
- Chemical energy of the chemicals present in the antiseptic.
- Chemical energy of the chemicals present in the digestive juice.

A.4.6. Organ

- The ability of the scent gland to produce appropriate chemicals that emit the scent.
- The composition of the scent, which is responsible for stimulating the sense of smell in insects.

- The ability of the hair to covert mechanical movement into ATP-driven changes in water pressure within the cells.
- Time taken to close the trap to be lesser than the time taken by the insect to escape.
- Direct link between water pressure within the tissue cells in the inner layers of the leaf and the lobes of the trap.
- The ability of the gland to produce antiseptic and digestive juices when triggered.
- The composition of the antiseptic, which is responsible for purifying and preventing decay of the insect.
- The composition of the digestive juice, which is responsible for breaking down the insect's fluids into basic chemicals.

A.4.7. Parts

- Nectar glands present on the inside of the leaf.
- Scent, which is made up of chemicals that stimulate insects in particular.
- Trigger hairs: up to six per half-leaf that are touch sensitive.
- Trap: a bivalved, convex leaf blade that is not hinged at its center.
- Gland that secretes the antiseptic and digestive juices.
- Antiseptic juice: made up of chemicals that react with the insect, purifying it and also preventing it from decaying.
- Digestive juice: made up of chemicals that react with the insect's body fluids, eventually breaking them down into basic chemicals.

A.5. Computer-understandable form for Venus flytrap example

ACTION

```
{
A1 $ V < feed > $
}
```

STATE

```
{
SS1 $ V < move > A < close > N < body > $
SS2 $ V < open > A < > N < trap > $
SS3 $ V < trap > A < > N < body > $
SS4 $ V < close > A < > N < trap > $
SS5 $ V < transform > A < > N < chemical > $
}
```

PHYPHENOMENON

```
{
PP1 $ V < produce > A < > N < chemical > $
PP2 $ V < stimulate > A < > N < sense > $
PP3 $ V < move > A < > N < hair > $
PP4 $ V < close > A < partially > N < part > $
PP5 $ V < move > A < > N < hair > $
PP6 $ V < close > A < completely > N < part > $
```

```
PP7 $ V < secrete > A < > N < chemical > $
```

```
PP8 $ V < prevent > A < chemical > N < reaction > $
```

```
PP9 $ V < transform > A < > N < chemical > $
```

```
}
```

PHYEFTECT

```
{
```

```
PE1 $ Stimulus-response effect $
```

```
PE2 $ Lever effect $
```

```
PE3 $ Lever effect $
```

```
}
```

INPUT

```
{
```

```
I1 $ A < electrical > A < > N < signal > $
```

```
I2 $ V < > A < > N < chemical > $
```

```
I3 $ V < > A < > N < force > $
```

```
I4 $ V < > A < fluid > N < pressure > $
```

```
I5 $ V < > A < > N < force > $
```

```
I6 $ V < > A < chemical > N < energy > $
```

```
}
```

ORGAN

```
{
```

```
O1 $ The ability of the scent gland to produce appropriate chemicals that emit the scent $
```

```
O2 $ The composition of the chemical emitting the scent, which is responsible for stimulating the sense of smell in insects $
```

```
O3 $ Ability of the hair to covert mechanical movement into ATP-driven changes in water pressure within the cells $
```

```
O4 $ Link between water pressure within the tissue cells in the inner layers of the leaf and the lobes of the trap $
```

```
O5 $ The ability of the gland to produce antiseptic and digestive juices when triggered $
```

```
O6 $ The composition of the antiseptic, which is responsible for purifying and preventing decay of the insect $
```

```
O7 $ The composition of the digestive juice, which is responsible for breaking down the insect's fluids into basic chemicals $
```

```
}
```

PARTS

```
{
```

```
P1 $ V < > A < > N < gland > $
```

```
P2 $ V < > A < > N < chemical > $
```

```
P3 $ V < > A < > N < hair > $
```

```
P4 $ V < > A < > N < trap > $
```

```
P5 $ V < > A < > N < hair > $
```

```
P6 $ V < > A < > N < gland > $
```

```
}
```

LINK

```

{
A1-SS1-PP1-PE1-I1-O1-P1
A1-SS1-PP2-PE1-I2-O2-P2
A1-SS2-PP3-PE1-I3-O3-P3
A1-SS3-PP4-PE2-I4-O4-P4
A1-SS3-PP5-PE1-I5-O3-P3
A1-SS4-PP6-PE3-I4-O4-P5
A1-SS4-PP7-PE1-I1-O5-P6
A1-SS4-PP8-PE1-I6-O6-P2
A1-SS5-PP9-PE1-I6-O7-P2
}

```

APPENDIX B: VARIABLE SPEED DRIVE WITHOUT GEARS (FRICTION DRIVE) EXAMPLE FROM ARTIFICIAL DATABASE

B.1. Function

This disk and roller, variable-speed friction drive can be used to transmit both high torque, as on industrial machines, and low torque, as in laboratory instruments. This mechanism performs best if used to reduce and not increase speed. It is also capable of reversing the direction of motion.

B.2. Structure

This drive consists basically of a disk and roller. Although the axes of the shafts of the disk and roller lie in the same plane, the axes of their surfaces lie in planes perpendicular to each other.

B.3. Behavior

The roller is moved rapidly on the disk. Its speed ratio depends on the operating diameter of the disk. The direction of relative motion of the shafts is reversed when the roller is moved past the center of the disk.

All friction drives have a certain amount of slip due to imperfect rolling of the friction members, but with effective design, the slip can be held constant, resulting in constant speed of the driven member. Compensation for variations in load can be achieved by placing inertia masses on the driven end. Springs or similar elastic members can be used to keep the friction parts in constant contact and to exert the force necessary to create the friction. Custom-made friction materials are generally recommended, but neoprene or rubber can be satisfactory. Normally only one of the friction members is made or lined with this material, and the other is metal.

The animation shown alongside demonstrates the functioning of this variable speed drive.

B.4. Human-understandable form for variable speed drive without gears (friction drive) example

B.4.1. Explanation

This mechanism transmits power from one shaft to another, which can also be interpreted as a change of state from the absence of contact to its presence, between the friction disk and the adjustable roller.

The mechanism can also be used for obtaining variable output speeds. This can also be interpreted as a change of state from the absence of contact to its presence, between the adjustable roller and the friction disk at various points on the surface.

The whole process is accomplished in a series of steps as described below.

The friction disk is fixed on the input shaft, which in turn is attached to the motor. Thus, the friction disk forms a revolute pair with the frame (part). The motor applies a torque to the shaft (input), which activates Newtonian laws of motion (physical effect), and rotates the friction disk (physical phenomenon). This requires a 1 degree of freedom of motion between the shaft and the friction disk in the direction of rotation (organ).

The friction disk forms a sliding pair with the adjustable roller (part). As the friction disk rotates (input), the adjustable roller rotates as well (physical phenomenon) activating the friction effect (physical effect) due to the friction developed between the contacting friction surfaces (organ).

The adjustable roller forms a prismatic pair with the shaft (part). The rotation of the adjustable roller (input) causes the shaft to rotate as well (physical phenomenon); by activating the "No two bodies can occupy the same space at the same time" effect (physical effect). The rotation requires a 0 degree of freedom of motion (in the direction of motion) to exist between the two bodies (organ).

Because the adjustable roller is connected to the shaft by a prismatic joint (part), the position of the roller on the shaft can be changed (physical phenomenon). This is achieved by applying a force on the roller (input), which slides it along the spline, activating the Newtonian Laws of motion (physical effect).

There is frictional contact between the friction disk and the adjustable roller (part). Thus, as the position of the adjustable roller on the shaft is changed (input), there is a difference in the diameter of the disk at the point of contact with the adjustable roller (organ). This activates Newtonian laws of motion (physical effect), and thus the speed of the output shaft is altered (physical phenomenon).

The friction disk is in contact with the adjustable roller (part). As the friction disk rotates, the adjustable roller rotates as well, due to the friction developed between the contacting surfaces. This activates the friction effect (physical effect). If the adjustable roller is moved past the center of the rotating disk (input), the direction of rotation of the roller will reverse (physical phenomenon). Therefore, the direction of rotation of the roller depends on its position on the disk, with respect to its center (organ).

B.4.2. Action

- Using this drive, the output speed can be changed easily.
- This drive also transmits power from the motor to the output shaft.
- This drive reverses the direction of rotation.

B.4.3. State

- Absence of contact between friction disk and adjustable roller.
- Presence of contact between friction disk and adjustable roller.
- Presence of contact between various points on the surface of friction disk and adjustable roller.

B.4.4. Physical phenomenon

- The rotation of the friction disk that is attached to the motor shaft.

- The rotation of the adjustable roller that is in contact with the friction disk.
- The rotation of the output shaft on which the roller is mounted.
- The position of the adjustable roller is altered according to the speed requirement.
- The speed is changed depending on the position of the adjustable roller.
- The direction of rotation can be reversed if the roller's position past the center of the disk.

B.4.5. Physical effect

- Newtonian laws of motion.
- The basic law "No two bodies can occupy the same space at the same time."
- Friction effect: the friction generated between the bodies in contact results in the motion being transferred.

B.4.6. Input

- The motor applies a torque to the shaft, which in turn, rotates the friction disk.
- For rotation of the adjustable roller to be possible, contact between itself and the disk must be maintained.
- The rotation of the adjustable roller that is in contact with the friction disk.
- A force is applied to the adjustable roller in order to change its position on the splined shaft.
- The position of the adjustable roller is altered according to the speed requirement.
- The position of the adjustable roller must be set on the other side of the center of the disk.

B.4.7. Organ

- One degree of freedom of motion between the shaft and the first disk in the direction of motion.
- The friction material on the surface of the components.
- Zero degree of freedom of motion between the adjustable roller and the splined shaft in the direction of motion.
- The diameter of the disk at the point of contact between the adjustable roller and the disk.
- The relative position of the roller depending on the center of the disk.

B.4.8. Parts

- The friction disk forms a revolute pair with the frame.
- The friction disk is in contact with the adjustable roller.
- The adjustable roller forms a prismatic pair with the shaft.

B.5. Computer-understandable form for variable speed drive without gears (friction drive) example

ACTION

```
{
A1 $ V < change > A < > N < speed > $
A2 $ V < transmit > A < > N < power > $
```

```
A3 $ V < reverse > A < rotating > N < direction > $
}
```

STATE

```
{
SS1 $ V < maintain > A < > N < gap > $
SS2 $ V < make > A < > N < contact > $
SS3 $ V < change > A < > N < position > $
}
```

PHYPHENOMENON

```
{
PP1 $ V < rotate > A < > N < disk > $
PP2 $ V < rotate > A < > N < roller > $
PP3 $ V < rotate > A < > N < shaft > $
PP4 $ V < change > A < > N < position > $
PP5 $ V < change > A < > N < speed > $
PP6 $ V < reverse > A < rotating > N < direction > $
}
```

PHYEFFECT

```
{
PE1 $ Newtonian laws of motion $
PE2 $ No two bodies can occupy the same space at the same time $
PE3 $ Friction effect $
}
```

INPUT

```
{
I1 $ V < apply > A < > N < torque > $
I2 $ V < maintain > A < > N < contact > $
I3 $ V < rotate > A < > N < roller > $
I4 $ V < apply > A < > N < force > $
I5 $ V < change > A < > N < position > $
I6 $ V < move > A < past > N < center > $
}
```

ORGAN

```
{
O1 $ 1 dof $
O2 $ friction material $
O3 $ 0 dof of motion in the dir of motion $
O4 $ ratio of diameters $
O5 $ position of roller depending on the center $
}
```

PARTS

```
{
P1 $ V < > A < > N < disk > $
P2 $ V < > A < > N < frame > $
P3 $ V < > A < > N < roller > $
```

P4 \$ V < > A < > N < shaft > \$
 P5 \$ V < > A < revolute > N < pair > \$
 P6 \$ V < > A < prismatic > N < pair > \$
 P7 \$ V < > A < > N < contact > \$
 }
 LINK
 {
 A2-PP1-SS1-PE1-I1-O1-P1-P2-P5
 A2-PP2-SS2-PE3-I2-O2-P1-P3-P7
 A2-PP3-SS2-PE2-I3-O3-P3-P4-P6
 A1-PP4-SS3-PE1-I4-O1-P3-P4-P6
 A1-PP5-SS3-PE1-I5-O4-P1-P3-P7
 A3-PP6-SS3-PE1-I6-O5-P1-P3-P7
 }

APPENDIX C: EXAMPLES OF VERB, NOUN, AND ADJECTIVE CLUSTERS

C.1. Verb clustering

The following gives an example of a verb cluster with the general verb “separate,” which has five clusters containing more specific verbs that are similar to each other but different from verbs in the other clusters:

{GV = General verb, SP = Specific verb
 GV \$ separate free \$
 SP \$ remove evacuate \$
 SP \$ dismantle disengage detach disconnect release \$
 SP \$ distil filter clean wash rinse brush \$

SP \$ cut chop slice tear bore drill shear \$
 SP \$ bomb blast burst explode pulverize \$}

C.2. Noun clustering

{solid object metal material substance member body}

C.3. Adjective clustering

{fast quick rapid instant}

Amaresh Chakrabarti is an Associate Professor at the Center for Product Design and Manufacturing, Indian Institute of Science (IISc), Bangalore, India. He obtained his PhD from the University of Cambridge, Cambridge, UK. Dr. Chakrabarti’s research interests are creativity and synthesis, ecodesign, collaborative design, and design research methodology.

Prabir Sarkar is a PhD student at the Centre for Product Design and Manufacturing, IISc, Bangalore, India. He received an MDes degree from IISc and worked in industry for 3 years before joining IISc. Mr. Sarkar’s research interests are design creativity and biomimicry.

B. Leelavathamma is a Research Associate at the Centre for Product Design and Manufacturing, IISc, Bangalore, India. She has an MS (Eng) in civil engineering from IISc. Her research interests are foundation design, programming, and biomimicry.

B.S. Nataraju is the head of DAD, Space Mechanisms Group of the Indian Space Research Organisation (ISRO) Satellite Centre, Bangalore, India. He has analyzed several space mechanisms for ISRO. His research interests are mechanisms and foldable structures.