

# Development of a Novel Concept of a Lunar Vehicle Mobility System Using a Systematic Design Framework and IDEA-INSPIRE

Srinivasan V\*, Ujjwal Pal\*, Ranjan BSC\*, Sai Prasad Ojha\*, Amaresh Chakrabarti\* and Ranganath R\*\*

\*Centre for Product Design and Manufacturing, IISc, Bangalore, India.

E-mail: {srinivasan, ujjwal, ranjan, ac123}@cpdm.iisc.ernet.in; saiprasadojha@gmail.com

\*\* Spacecraft Mechanisms Group, ISRO Satellite Centre, Bangalore, India. E-mail: rrrr@isac.gov.in

**Abstract**— The objective of this paper is to demonstrate the application of a systematic design framework and IDEA-INSPIRE to design a lunar vehicle mobility system and to further develop and validate, physically and virtually, one concept of the mobility system. The framework combines activities (Generate, Evaluate, Modify, Select: GEMS), outcomes (State change, Action, Parts, Phenomenon, Input, oRgans, Effect: SAPPPhIRE) and co-evolving requirements and solutions (req-sol). The framework is divided into two stages: Requirements Exploration Stage (RES) and Solutions Exploration Stage (SES), and allows detailed exploration of the outcomes for requirements and solutions. IDEA-INSPIRE is a computer-based tool that suggests analogically relevant solutions from a database of natural and engineered systems, to support idea-generation during the early stages of designing. Four major requirements were identified for the mobility system: mobility, handling gradient, stability and steering. A variety of alternative ideas are developed for each of these requirements using the framework and IDEA-INSPIRE. The ideas are combined to create twenty concepts. The most suitable concept was chosen; physically modeled and tested using LEGO MINDSTORMS™ robotics kit; virtually modeled and tested using SolidWorks™ and MSC ADAMS™.

**Keywords**—Framework; IDEA-INSPIRE; novelty; mobility system; lunar vehicle; concept

## I. INTRODUCTION

Designing faces multiple issues of: strong competition in market, forcing industries to produce new products periodically at minimal cost and environmental impact; communication among multiple teams from different disciplines that are involved in designing; addressing complex requirements from all design stages including disposal and recycling; etc. These issues call for a systematic approach as reliance on spontaneous ideas or incremental development may not solve all of these each time. A number of researchers have stressed the need for a systematic approach to designing [1, 2] and researchers [3, 4] have pointed out the benefits of a systematic approach.

Researchers in the past have shown inspiration to be useful for exploration and discovery of new solution spaces in designing [5-7]. Research has shown that the use of stimuli can lead to more ideas being generated during problem-solving [8] and stimulus rich creativity techniques have a positive influence on creativity of outcomes [9]. Analogy has been considered as a potent

source for inspiring novel idea generation [10, 11]. Systems in natural and engineered worlds have a wide range of diverse functionality, behaviour and structure, which can be seen as a rich source of inspiration for idea-generation during designing. Researchers [12, 13] have understood the importance of learning from nature and have made attempts at learning from nature from a perspective of product development. However, exploring a diverse range of ideas is difficult and may lead to many ideas not being explored.

The objectives of this paper are to: (a) demonstrate the results of application of a systematic design framework in conjunction with IDEA-INSPIRE to design alternative novel concepts for the mobility system of a lunar vehicle, and, (b) develop and validate a physical and a virtual model of a chosen concept.

## II. GEMS OF SAPPPhIRE AS REQ-SOL

A model of designing is defined as a description of how designing is currently done; a framework for designing is defined as a prescription of how designing should be done so as to improve some characteristics of designing. In [14], the authors stressed on including activities, outcomes, requirements and solutions in design models and frameworks. After a comprehensive literature survey in [14] of existing models and frameworks, the authors identified: Generate, Evaluate, Modify and Select (GEMS) as activities; State change, Action, Parts, Phenomenon, Input, oRgans and Effect (SAPPPhIRE) as outcomes; and co-evolving requirements and solutions (req-sol), which were combined together to create an integrated model of designing – GEMS of SAPPPhIRE as req-sol. The integrated model was evaluated using observational studies of designing sessions where the model was not followed to check if the model was inherently used in designing. It was observed that: (a) all the identified constructs were found in all the designing sessions, (b) high numbers of action-, input- and part-level descriptions were found and low numbers of state change-, phenomenon-, effect- and organ-level descriptions were found in all the designing sessions, i.e. not all outcomes were equally explored; and (c) during designing, application of activities on outcomes lead to evolution of outcomes as requirements or solutions. In another study [15], it was reported that novelty of concepts depended on variety of concepts and size of the space of explored outcome constructs; higher values of novelty and variety

are reported if higher number of outcomes at higher abstraction levels are explored and the values decreased with the abstraction level of outcomes. Based on the above observations, a systematic framework for designing – GEMS of SAPPPhIRE as req-sol – was proposed as a support for enhancing novelty of concepts in [16]. In the framework, the activities are applied to all the outcomes for requirements and solutions. The framework was divided into two stages: Requirements Exploration Stage (RES) and Solutions Exploration Stage (SES). The following steps have to be followed in the framework:

*RES:*

- (a) Generate all possible requirements for a given design problem to be solved. Classify the requirements into one of the SAPPPhIRE constructs.
- (b) Evaluate the requirement(s) to check that they do not contradict and are feasible within the scope of the project.
- (c) If the requirements contradict or not feasible, modify them and repeat step (b).
- (d) If the requirements do not contradict and are feasible, select them.

*SES:*

This stage started by generating solution(s) at the action-level and culminated by selecting solution(s) at the part-level. The stage is sub-divided into: Action-level solution exploration; State change-level solution exploration; Phenomenon-level solution exploration; Effect-level solution exploration; Input- and Organ-level solution exploration; and Part-level solution exploration.

*Action-level Solution Exploration:*

The following steps have to be followed at this stage:

- (a) Based on the selected action-level requirement(s), generate an action-level solution.
- (b) Evaluate the action-level solution against the selected action-level requirement(s) from RES to check if the solution violates the requirement(s).
- (c) Select the action-level solution if it does not violate.
- (d) Modify the action-level solution if it violates and repeat step (b).
- (e) Repeat steps (a)-(d) to get more solution(s) at the action-level.

*State change-level Solution Exploration:*

The following steps have to be followed at this stage:

- (a) Based on a selected action-level solution, generate a state change-level solution.
- (b) Evaluate the state change-level solution against: action-level solution from which it was generated and selected state change-level requirement(s) from RES, to check if the solution violates both.
- (c) Select the state change-level solution if it does not violate.
- (d) Modify the state change-level solution if it violates even one of the two and repeat step (b).
- (e) Repeat steps (a)-(d) to get more state change-level solution(s) from: (i) the action-level solution and (ii) all the other action-level solution(s).

*Phenomenon-level Solution Exploration:*

The following steps have to be followed at this stage:

- (a) Based on a selected state change-level solution, generate a phenomenon-level solution.

- (b) Evaluate the phenomenon-level solution against: state change-level solution from which it was generated and selected phenomenon-level requirement(s) from RES, to check if the solution violates both.
- (c) Select the phenomenon-level solution if it does not violate.
- (d) Modify the phenomenon-level solution if it violates even one of the two and repeat step (b).
- (e) Repeat steps (a)-(d) to get more phenomenon-level solutions from: (i) the state change-level solution and (ii) all the other state change-level solution(s).

*Effect-level Solution Exploration:*

The following steps have to be followed at this stage:

- (a) Based on a selected phenomenon-level solution, generate an effect-level solution.
- (b) Evaluate the effect-level solution against: phenomenon-level solution from which it was generated and selected effect-level requirement(s) from RES, to check if the solution violates both.
- (c) Select the effect-level solution if it does not violate.
- (d) Modify the effect-level solution if it violates even one of the two and repeat step (b).
- (e) Repeat steps (a)-(d) to get more effect-level solutions from: (i) the phenomenon-level solution and (ii) all the other phenomenon-level solution(s).

*Input- and Organ-level Solution Exploration:*

The following steps have to be followed at this stage:

- (a) Based on a selected effect-level solution, generate an input- and the corresponding organ-level solution.
- (b) Evaluate the input-/organ-level solution against: effect-level solution from which it was generated and selected input-/organ-level requirement(s) from RES, to check if the solution violates both.
- (c) Select the input- and organ-level solutions if both of them do not violate.
- (d) Modify the input- and organ-level solution even if one of them violates one of the two and repeat step (b).
- (e) Repeat steps (a)-(d) to get input- and organ-level solution from the other selected effect-level solutions.

*Part-level Solution Exploration:*

The following steps have to be followed at this stage:

- (a) Based on a selected organ-level solution, generate a part-level solution.
- (b) Evaluate the part-level solution against: organ-level solution from which it was generated and selected part-level requirement(s) from RES, to check if the solution violates both.
- (c) Select the part-level solution if it does not violate.
- (d) Modify the part-level solution if it violates even one of the two and repeat step (b).
- (e) Repeat steps (a)-(d) to get more part-level solutions from: (i) the organ-level solution and (ii) all the other organ-level solution(s).

The framework allows a detailed exploration of all the outcomes for both requirements and solutions, thereby increasing the number of ideas and concepts. This can potentially increase the variety and hence, novelty of

concepts. Overall, the framework gives knowledge of the process i.e. the steps to be carried out in designing.

### III. IDEA-INSPIRE

IDEA-INSPIRE [6] is an interactive, computer-based tool that provides analogically relevant triggers or stimuli from existing natural and engineered systems to designers, to assist them during the idea-generation stage of designing. The software contains two databases of: (a) natural systems and, (b) engineered systems. The tool uses a wide variety of diverse motions that natural and engineered systems exhibit as a source of inspiration for solving product design problems, especially in inspiring creativity and innovation. Each entry in the database contains verbal descriptions, pictorial descriptions, and video descriptions or animations. The verbal description of each entry is done using Function-Behaviour-Structure (FBS) [17] and SAPPPhIRE [6] models. The tool can be used in two modes. In the first mode, when a design problem is not well-defined, the designer(s) can browse through the database to view related entries, get interested in some of them and may decide to focus on them in order to use the ideas in the entries to solve the problem. In the second mode, when a design problem is well defined, the designer can directly define the problem in the tool using constructs of the SAPPPhIRE model and use reasoning procedures of the tool for automated search for stimuli to solutions. As a response, the tool gives a list of entries from its database, which are ranked according to its relevance to the problem searched. The problem search is represented using a combination of verb, noun and adjective. For example, “move fluid fast” (verb: move, noun: fluid, adjective: fast). One of the verb, noun or adjective can be taken as a demand; the tool ranks the search results based on the similarity to the demand. Three kinds of search are possible – direct, combined and complex. In direct search, only one problem search with a demand is used. In combined search, two or more problem searches with one demand each are used. In complex search, a problem search with a demand is used first and the search results are refined by searching among these results in other fields. Overall, IDEA-INSPIRE provides product knowledge for designing.

### IV. APPROACH

The following approach is followed to meet the objectives of the paper:

- (a) Identify requirements for the mobility system of a lunar vehicle using the framework.
- (b) Develop solutions using the framework and IDEA-INSPIRE by: developing alternative ideas for each action-level requirement and combining the ideas of different action-level requirements to create alternative concepts.
- (c) Choose a concept from among the alternative concepts.
- (d) Perform physical modeling and testing of the concept. Modeling is done using LEGO Mindstorms™ robotics kit. A physical model of a terrain is built to test the physical model. The terrain is made of a surface whose co-efficient of static friction is 0.58. The terrain consists of a path for ascent and descent whose angles can be adjusted between 0°-50°.

- (e) Perform virtual modeling and testing of the selected concept. SolidWorks™ is used for CAD modeling and static analysis to test performance, strength and durability. MSC ADAMS™ is used for motion analysis in different surface conditions.

### V. RESULTS

#### A. RES

From the literature survey [18-20], the initial requirements list was as follows: mass of vehicle: 10 kg; mass of payload: 10 kg; size of vehicle: 600 x 500 x 200 mm; vehicle speed: 10 – 20 mm/s; launch and landing load in all directions: 40 g ( $g = 9.8 \text{ ms}^{-2}$ ); handle gradient:  $\pm 30^\circ$ ; prevent toppling of vehicle; vehicle should have obstacle navigation capabilities; provide equal distribution of load in static and dynamic conditions (to avoid unbalanced force or moment); provide mobility and steering functions; provide strong off-road abilities in both smooth and rough terrain (to face unstructured environments); provide stability during motion: ensure optimal ground contact of all wheels at any time (ground contact provides normal force, ensures traction, and thereby reduces slip); ensure centre of gravity of vehicle is as low as possible; provide maximum ground clearance (charged lunar dust has tendency to cling to non-grounded conductor surfaces of vehicle and erode the surfaces); minimise wheel slip (improves terrain navigation ability); ensure normal force on each wheel regardless of the position of the vehicle is approximately equal (results in equal traction forces on all wheels thereby, reducing slip); protect body of vehicle from lunar environment having extreme temperatures, vacuum and high-energy radiation; provide accessibility for all vehicle components for easier pre-launch testing and replacement; ensure that structure of vehicle can support all components; provide unobstructed view for cameras and sensors; protect on-board equipment and structure of vehicle in the event of collision at maximum speed; ensure mechanical robustness, simplicity and reliability of vehicle; minimise power consumption of vehicle; ensure that one wheel can support entire weight of vehicle; ensure that traction stress does not exceed maximum shear stress of the lunar soil (when traction stress exceeds shear stress, soil fails to support and starts to move loosely, wheel gets stuck at same place, digs hole and sinks in it); demonstrate operation of physical model of vehicle using a crude remote control.

A meeting of the design team (the authors of this paper) to evaluate, modify and select requirements led to pruning of the requirements list by categorising related requirements under the same category, keeping relevant requirements for the project and deleting those which cannot be tested within the scope of the project. The requirements are categorised according to one of the SAPPPhIRE constructs: mass of vehicle: 10 kg (organ); mass of payload: 10 kg (organ); size of vehicle: 600 x 500 x 200 mm (organ); vehicle speed: 10 – 20 mm/s (input); provide mobility capabilities [start; stop] (action); provide steering capabilities [veer left or right] (action); handle gradient of  $\pm 30^\circ$  (handling gradient: action); and, provide stability which includes prevention of toppling, equal distribution of load, equal weight on all wheels, minimisation of wheel slip, etc. (provide stability: action).

## B. SES: Development of Ideas

From an action-level requirement, alternative solutions are produced at action-, state change-, phenomenon-, effect-, input-, organ- and part-levels by following the steps in the framework. Figure 1 shows a snapshot of solutions at different abstraction levels for the action-level requirement – provide mobility. For example, *provide mobility* [action-level requirement] can be satisfied by several alternative action-level solutions: move object; change state of object, transport object and change state to revert back to original state; disassemble object, transport object and assemble object, etc., where the term object refers to the one that is provided mobility. *Move object* can be satisfied by alternative state change-level solutions: change in linear position, change in angular position, change in linear and angular positions, etc. Change in an object's linear position can be achieved by several alternative phenomenon-level solutions: translation, expansion, compression, etc. Expansion can be achieved by alternative effect-level solutions: force-deflection

effect,  $x = \frac{F}{k}$  ; linear expansion-temperature effect of

solids,  $\Delta x = x\alpha\Delta T$  ; stress-strain effect,  $x = \frac{\sigma l}{E}$  , etc.

Force-deflection effect can be activated by applying a force (input-level solution) on a non-rigid object that has a non-zero stiffness constant and ensuring that the expansion takes place in the direction of force (organ-level solution). The set of organ-level solutions can be embodied into alternative part-level solutions: beam in tension, beam in compression, tension spring, compression spring, all fixed at one end and free at the other end as shown in Figure 1. Similar steps were carried out to determine the different ways in which, for instance, force which was used as input for the force-deflection effect, can be supplied. IDEA-INSPIRE was used when the designers got stuck at some level of abstraction or were exhausted producing solutions when working without IDEA-INSPIRE. For instance, a problem search of *move object* returned eighty entries and the following entries were interesting to the designers (number within bracket shows the relevance percentage to the problem search): lobster (70.8), bushbaby (70.8), baboon (70.8), chimp (70.8), crab walking (70.8), cheetah running (70.8), gecko lizard (70.8), millipede deployment (70.8), kangaroo jumping (70.8), penguin waddling (70.8), ostrich running (70.8), desert beetle (70.8), elevator (66.7), Sea anemone somersaulting (12.6), dandelion seeds (12.6) and balloon (8.3). The above procedure is repeated for all the other action-level requirements.

## C. SES: Development of Concepts

A concept is defined here as a solution that satisfies all the requirements. The part-level solutions of different action-level requirements are combined together to create concepts. Since there are many alternative part-level solutions for each action-level requirement, and many action-level requirements, potentially many concepts can be created. In this project, twenty concepts were created and most of them satisfied the requirements.

## D. Evaluation and Selection of Concepts

The twenty concepts were given to designers from Spacecraft Mechanisms Group of ISRO to evaluate the

concepts and select a suitable concept. The designers selected the concept shown in Figure 2, because it was simple and had the potential to satisfy all the requirements. This concept consists of legged wheels with an ability to convert into a walking robot.

## E. Physical Modeling and Testing of Selected Concept

The selected concept required a large number of actuators which could potentially increase the power consumption. Due to the constraints in the availability of actuators in LEGO Mindstorms™ robotics kit, the concept was modified by combining it with another concept (shown in Figure 3). One other constraint in the physical model of the combined concept was that the springs available in the robotics kit were not sufficient to support the weight of the vehicle. The concept was further modified by including a platform and a lifting mechanism to move the platform up or down. The platform bears the payload of the vehicle and this shifts the centre of gravity closer to the ground, thereby also adding more stability to the vehicle. For obstacles with size less than the chassis height of the vehicle, the lifting mechanism lifts the platform so that the vehicle can go over the obstacle. For obstacles of other sizes, the vehicle goes around or climbs over the obstacle. A 1:2 sized physical model of the concept was built; four motors were used, one for each wheel; two additional motors were used for operating the lifting mechanism (Figure 4). Other specifications of the physical model are: mass: 1.05 kg; size of vehicle: 290 x 220 x 100 mm; power source: Robotics Command Explorer (RCX): (9V, 6.3 W). In the physical model, an obstacle is detected by using a touch sensor. Since mass is proportional to the volume, the vehicle should be able to carry a load of 2.5 kg. However, due to the limited capacity of the motors, it was not able to carry more than 1 kg load, and could not clear a steep obstacle of the size of the radius of the wheels.

A remote control was used for the demonstration of the vehicle's operation. The maximum speed of the vehicle was found to be 24 mm/s. The vehicle was able to ascend and descend 30° terrain with a co-efficient of static friction of 0.58. Skid steering was used in the vehicle for it to veer directions. The vehicle was stable during rest and motion, and did not topple during rest or in motion. Small-sized obstacles were overcome by lifting the platform and going over the obstacle. Large-sized obstacles were avoided by steering the vehicle around the obstacles.

## F. Virtual Modeling and Testing of the Concept

This concept was modelled in CAD using Solidworks™. Figure 5 shows different views of the concept.

Virtual simulations of the vehicle revealed that a vehicle of the given size of 600 x 500 x 200 mm was able to withstand a load of 20 kg, including the payload. Virtual simulations of the model using MSC ADAMS™ revealed that the model was able to ascend and descend a terrain with 30 degrees slope and co-efficient of static friction of 0.6. Virtual simulations also revealed that the concept was able to steer using skid-steering, go around obstacles. The motion simulation also revealed that the vehicle was stable during rest and motion, did not topple or overturn.

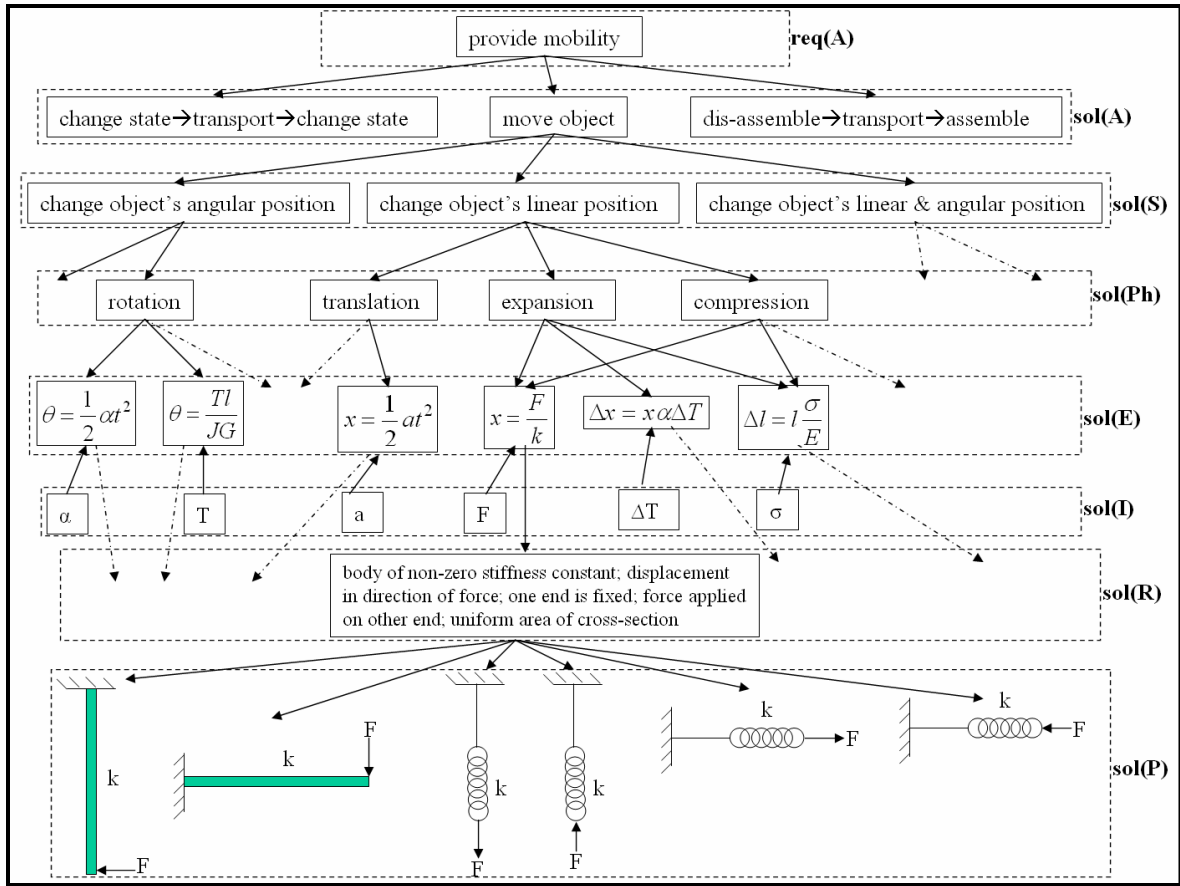

Figure 1: Some Ideas for Mobility

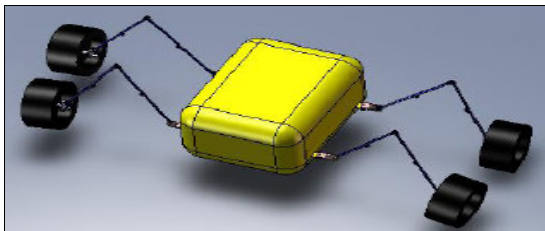

Figure 2: Selected Concept

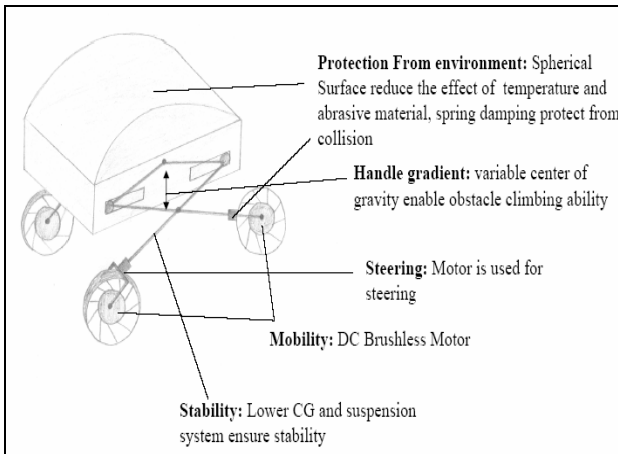

Figure 3: Another concept

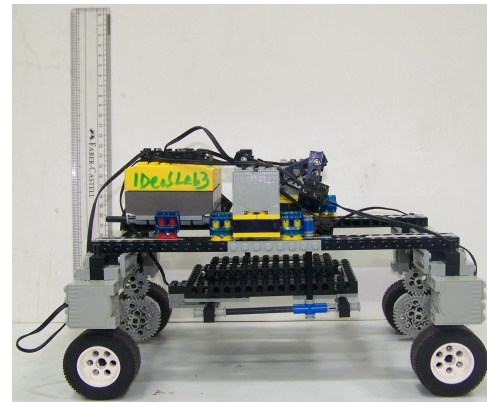

Figure 4: Physical Model of Final Concept

### G. Improvement of IDEA-INSPIRE

The design process helped identify new functions that must be included for the mobility system. During RES when literature was explored to gain clarity, some ideas that were found from literature, but not included by IDEA-INSPIRE were later added to IDEA-INSPIRE as new entries. For example, for protection from environment, the idea of using  $\text{TiO}_2$ -coating as a solution was found from literature and  $\text{TiO}_2$ -coating was added to the IDEA-INSPIRE as a new entry. Table 1 shows the new entries added. Thus, the experience of designing the mobility system for a lunar vehicle using the framework and IDEA-INSPIRE produced a

novel concept and also improved IDEA-INSPIRE with new entries.

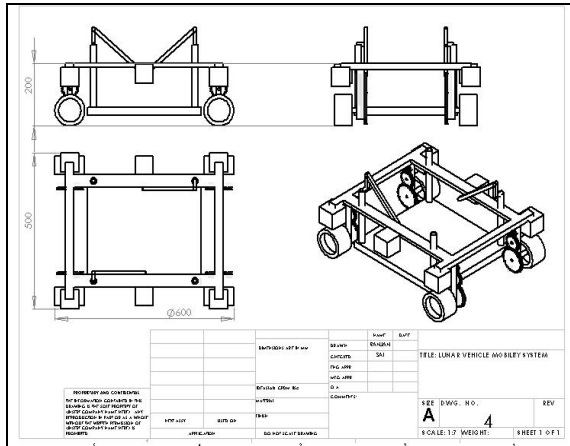

Figure 5: CAD drawing of the concept

TABLE I. NEW ENTRIES IN IDEA-INSPIRE

Sub-system	New Entries
Navigation	caterpillar; frog; gecko; Australian lizard; spider; cockroach; crab
Steering	skid; differential; power
Brake	hydraulic; disk; drum; electromagnetic; antilock braking system
Shock absorber	viscous damper; leaf spring; compression helical spring; tension helical spring; torsion spring
Drive/motor	DC motor; brushless DC motor; AC induction motor; stepper motor; gear type hydraulic motor; vane type hydraulic motor
Cooling system	air cooling system; radiator; water cooling system; swamp cooler; vacuum flask; sweating; TiO <sub>2</sub> coating
Actuator	magnetostrictive actuator; piezoelectric actuator; pneumatic actuator; potentiometer; skeletal muscle
Sensor	seismograph; bat echolocation; cricket acheta; ear; electrical eel; eyes; nose

## VI. SUMMARY

The paper described the results of applying a systematic framework for designing in conjunction with IDEA-INSPIRE for designing a novel concept of the mobility system of a lunar vehicle. Several requirements were identified for the mobility system. A wide variety of ideas were produced using the framework and IDEA-INSPIRE, which were then combined to create concepts. The use of this combination suggests an increase in efficiency of designers by enlarging their idea space and concept space, thereby improving the chances of novelty. One of the concepts was chosen for physical and virtual modeling and testing. The results revealed that the concept satisfied the

requirements. The design of mobility system also improved IDEA-INSPIRE by the addition of new entries.

## ACKNOWLEDGMENT

We thank ISRO-IISc Space Technology Cell for funding this project, and the Spacecraft Mechanisms Group of ISRO Satellite Centre, Bangalore, for its valuable inputs and support.

## REFERENCES

- [1] G. Pahl and W. Beitz, *Engineering Design: A systematic approach*. Spriger-Verlag, UK, 1996.
- [2] V. Hubka and W. Eder, "Theory of technical Systems and engineering design synthesis," *Engineering Design Synthesis-Understanding, Approaches and Tools*, (A. Chakrabarti, Ed.) Springer-Verlag, 2002, 49-65.
- [3] R. Cooper, "Major new products: What distinguishes the winners?," *J. Product Innovation Management*, 10, 1993, 91-111.
- [4] L. Blessing, "A process-based approach to computer-supported engineering design", PhD Thesis, University of Twente, The Netherlands, 1994.
- [5] T. Murakami and N. Nakajima, "Mechanism Concept retrieval using configuration space", *Research in Engineering Design*, 9, 1997, 9-11.
- [6] A. Chakrabarti, P. Sarkar, B. Leelavathamma and B.S. Nataraju, "A functional representation for aiding biomimetic and artificial inspiration of new ideas," *AI EDAM*, 19, 2005, 113-132.
- [7] P. Sarkar, "Development of a support for effective concept exploration to enhance creativity of engineering designers," PhD thesis, Indian Institute of Science, India, 2007.
- [8] M. Kletke, J. Mackay, S. Barr, H. and B. Jones, "Creativity in the organization: the role of individual creative problem solving and computer support", *Int. J. Human-Computer Studies*, 55, 2001, 217-237.
- [9] K. MacCrimmon and C. Wagner, "Stimulating ideas through creative softwares", *Management Science*, 40, 1994, 1514-1532.
- [10] S. Bhatta, A. Goel and S. Prabhakar, "Innovation in analogical design: A model-based approach, Proc. AID'94, 1994, 57-74.
- [11] L. Qian and J. Gero, "Function-Behavior-Structure paths and their role in Analogy-based design, *AI EDAM*, 10, 1996, 289-312.
- [12] S. Vogel, *Cat's Paws and Catapults: Mechanical Worlds of Nature and People*. W.W. Norton & Co., New York, 1998.
- [13] M. French, *Invention and Evolution: Design in Nature and Engineering*, CUP, USA, 1994.
- [14] V. Srinivasan and A. Chakrabarti, "Design for novelty - A framework?", Proc. of DESIGN2008, Croatia, 2008, pp. 227-232.
- [15] V. Srinivasan and A. Chakrabarti, "Investigating novelty-outcome relationships in engineering design", *AIEDAM*, 24, 2010, 161-178.
- [16] V. Srinivasan and A. Chakrabarti, "Designing novel artifacts: A novel systematic framework, Proc. of ICORD, India, 2009, 67-75.
- [17] J. Gero, "Design prototypes: A knowledge representation schema for design", *AI Magazine*, 11(4), 1990, 26-36.
- [18] NASA, "Lunar Surface Models", Report on Space Vehicle Design Criteria (Environment), 1969.
- [19] P. Berkelman, M. Chen, J. Easudes, J. Hancock, M. Martin, A. Mor, E. Rollins, A. Sharf, J. Silberman, T. Warren and D. Bapna, "Design of a day/night lunar rover", Carnegie Mellon University, USA, 1995.
- [20] T. Estier, Y. Crausaz, B. Merminod, M. Lauria, R. Piguat and R. Siegwart, "An innovative space rover with extended climbing abilities", Proc. of ROBOTICS2000, 2000, 333-339.